

IQ640

Load Cell Surge Protector

Manual – English 2.00



Introduction

The IQ640 load cell surge protector provides protection to the weighing system from severe over voltage and high power impulse currents.

The IQ640 contains unique triple stage surge protection circuitry to protect the signal, supply and shield lines. The first stage comprises of gas discharge tubes. Three terminal gas discharge tubes are used providing superior differential and common mode protection against conducted transients then surge protectors based on two terminal gas discharge tubes. Stage two comprises of current limiting fusible series surge resistors which in a rare case of extreme lightning or surge event will resort to a fail safe operation. This effectively disconnects the line from sensitive electronic equipment. The third stage comprises of a low capacitance over voltage diode clamp array. The diode array clamps fast transients to a safe level until the gas discharge tubes turn on.

The triple stage surge protector can handle higher transients than surge protectors based on voltage clamp diodes only.

1 Features

- Protects the weighing system from over voltage and high power impulse currents
- Protects signal, supply and shield lines
- High power triple stage surge protection
- Ground clamp provided on the exterior of the enclosure
- Suitable for AC or DC load cell excitation voltages
- Supports 4 or 6 wire load cells
- Clear lid for easy fault finding
- Shielded 6-wire connection to the load cell instrumentation
- Removable connectors for easy fault finding
- 1 year limited warranty

2 Dimension & Template Drawing

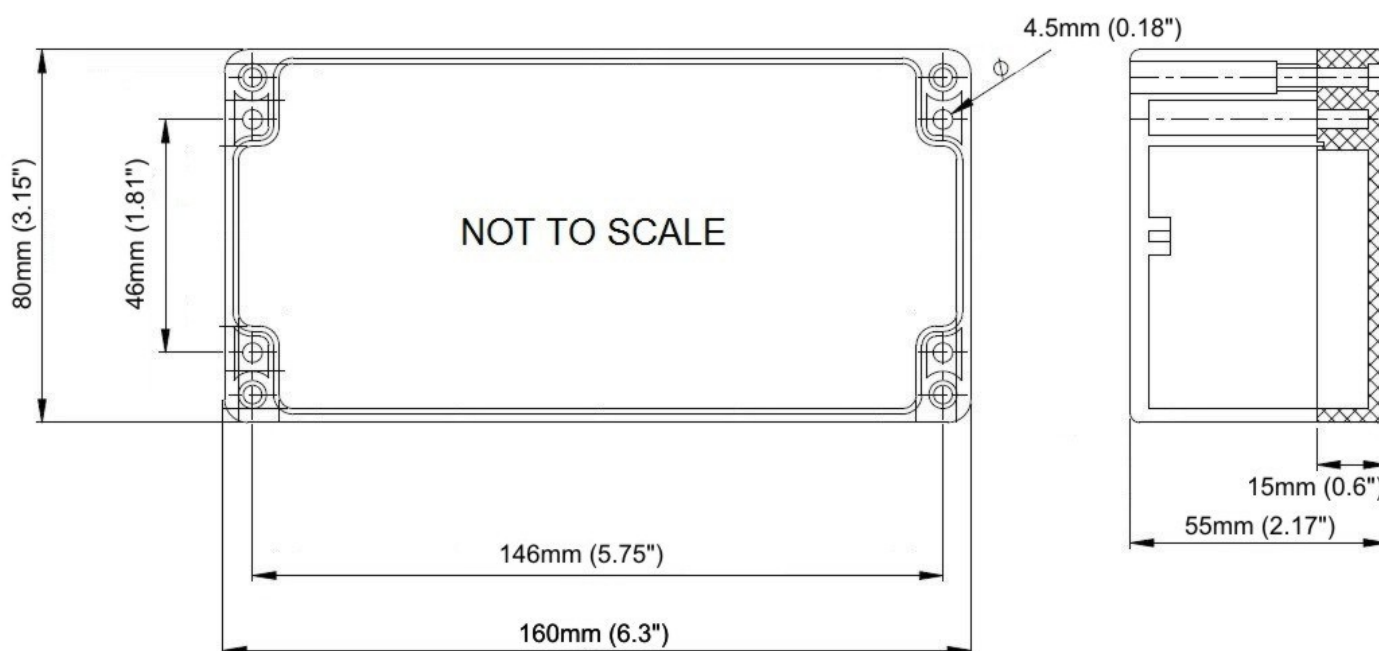

3 Specifications

Enclosure:	
Unit Dimensions	160x80x55mm (6.3x3.15x2.17")
Enclosure Sealing	Tongue and groove with Neoprene seal
Enclosure Material	Polycarbonate (grey base, clear lid)
Electrical:	
Stage 1 clamping voltage	+/-90V
Stage 2 series resistance	<=1 Ohm
Stage 3 clamping voltage	+/-24V
Maximum excitation voltage (symmetrical to ground)	22Vac or 32Vdc
Nominal excitation voltage (symmetrical to ground)	20Vac or dc
Leakage current at 20V	<10uA
Maximum surge current	5kA (8/20uS)
Main earth connection	External M8 Stud
Connections	Input/Output/Sense + Earth
Connector Ratings: (7 Way plug-in terminal blocks)	
Wire range	0.2-2.5mm ²
Wire stripping length	7mm
Gland Ratings:	
Clamping/sealing range	4-8mm (0.157-0.314") Diameter wire

Environmental Conditions:	
Operating temperature	-20°C to 60°C (-4°F to 140°F)
Storage temperature	-40°C to 80°C (-40°F to 176°F)
Operating and storage humidity	<95%, RH (non-condensing)
Weight	340g

4 Installation

The IQ640 load cell surge protector should be connected as close to the load cell or equipment been protected. For maximum protection the IQ640 can be installed at both ends of the system. Normally the surge protector will be installed between the junction box and the weighing equipment.

The IQ640 needs to be earthed for the protection circuitry to function correctly. Connect the external M8 stud to the equipment earth with the minimum length of cable as possible.

The IQ640 provides both a screened earth and an isolated screen by cutting the shield to earth link on the PCB.

If remote sensing is not used as in the case of 4-wire load cells then the system needs to be re-calibrated in order to cancel out the series resistance.

Notes:

- Tighten the gland nut until the rubber touches the cable completely and then tighten the nut with ½ turn (180 degrees)
- Install the IQ640 with the glands pointing downwards with cable drip loops (If the cables and load cell surge protector is exposed to water then bend a short downward loop in all cables near the cord grips so any water draining down the cables will drip off before reaching the load cell surge protector.
- If remote sensing is not used as in the case of 4-wire load cells then the system needs to be re-calibrated in order to cancel out the series resistance.

5 Ordering Information

IQ640 – Load Cell Surge Protector

6 Notice

Specifications of the products displayed herein are subject to change without notice. Infiniteq cc, or anyone on its behalf, assumes no responsibility or liability for any errors or inaccuracies.

Information contained herein is intended to provide a product description only. No license, express or implied, by estoppel or otherwise, to any intellectual property rights is granted by this document. Except as provided in Infiniteq's terms and conditions of sale for such products, Infiniteq assumes no liability whatsoever, and disclaims any express or implied warranty, relating to sale and/or use of Infiniteq products including liability or warranties relating to fitness for a particular purpose, merchantability, or infringement of any patent, copyright, or other intellectual property right.

The products shown herein are not designed for use in medical, life-saving, or life-sustaining applications. Customers using or selling these products for use in such applications do so at their own risk and agree to fully indemnify Infiniteq for any damages resulting from such improper use or sale.

7 Warranty

This product carries a warranty for a period of one year from date of purchase against faulty workmanship or defective materials, provided there is no evidence that the unit has been mishandled or misused. Warranty is limited to the replacement of faulty components and includes the cost of labor. Shipping costs are for the account of the purchaser.

Note: Product warranty excludes damages caused by unprotected, unsuitable or incorrectly wired electrical supplies and or sensors, and damage caused by inductive loads.

DISTRIBUTED BY: