

# XTreme - EFIS

## Electronic Flight Information System

### Operating Manual – English 3.02

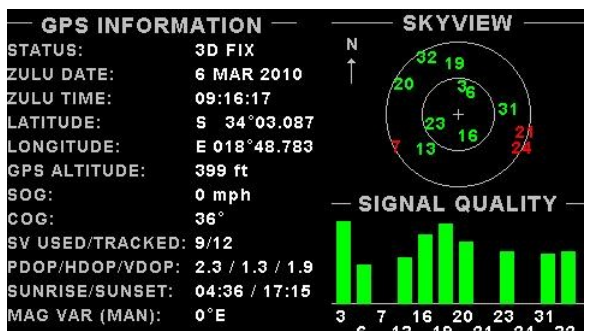
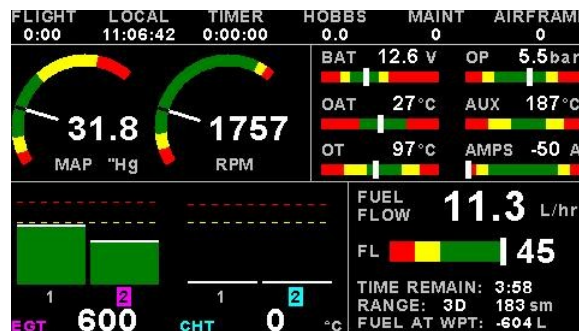
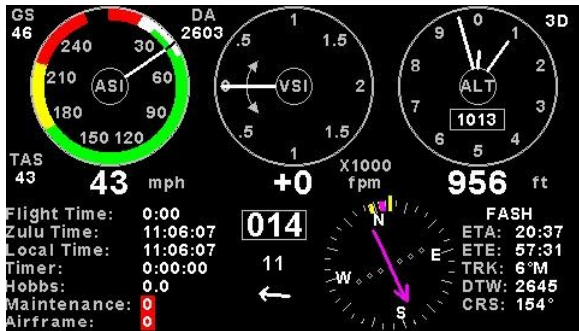

\*\*\*\* SAMPLE CHECKLIST \*\*\*\*  
 NORMAL TEXT FILE WITH .ECL EXTENSION  
 EACH LINE MUST BE TERMINATED IN CR  
 MAXIMUM 60 CHARS PER LINE  
 MAXIMUM 30 LINES PER CHECKLIST FILE

ROTAX ECU STATUS  
 LANE A DATA: NO  
 LANE B DATA: NO  
 ENGINE HOURS: 0.00  
 ECU HOURS: 0.00  
 ENGINE AMBIENT PRESSURE: 0hPa  
 LANE IS NOT IN CONTROL OF GENERATOR  
 POWER MODE  
 LANE IS COMMANDING GENERATOR B  
 WARNING LAMP OFF

**ROTAX**

# Introduction

The XTreme-EFIS is a compact, multifunction electronic flight information system intended as a main flight instrument in smaller aircraft or as a backup/secondary flight instrument in larger aircraft. The XTreme-EFIS, which fits a standard 3 1/8" (80mm) instrument panel hole, contains all the necessary functionality to replace several flight and engine monitoring instruments.

All information is displayed in an easy to read format on a high resolution wide viewing angle 4.3" sunlight readable color display.

The XTreme-EFIS light weight, small size and high level of functionality makes it an excellent choice for all types of non-certified aircraft.

## 1 Features

### Hardware:

- **Powerful 32 bit ARM processor**
- **4.3" high resolution 480x272, sunlight readable, wide viewing angle, 1000cd/m2 TFT LCD display**
- **LED backlight (brightness can be adjusted for low light flying conditions)**
- **Fits standard 3 1/8" (80mm) aircraft instrument panel hole**
- **SD Card interface for data recording, user splash screens, checklists, graphic information pages, firmware upgrades, navigation and route files**
- **2x RS232 communication ports (Altitude encoder / GPS NMEA out / External GPS in / UL Power interface / transponder interface)**
- **1x CAN communication port**
- **Rotary control plus 5 independent buttons for easy menu navigation and user input**
- **External alarm switch output for an external indicator lamp etc**
- **Built in 50 Channel GPS receiver with over 1 million effective correlators with high immunity to jamming**
- **Built in Accelerometer to measure G-Force and Slip**
- **GPS Time To First Fix (TTFF) of less than 1 second**
- **External active GPS antenna connection**
- **Support for an internal or an external GPS receiver**
- **Built in RTC (Real Time Clock)**
- **Wide input supply voltage range of 8 to 30V DC**
- **Built in voltage reversal and over voltage protection for harsh electrical environments**
- **Light weight design**

### EFIS:

- **Attitude display. Note (1)**
- **Magnetic heading indication. Note (2)**
- **Heading bug**
- **Precision altimeter from -1500ft up to a maximum of 35 000ft (-457m to 10668m). Altitude can be displayed in feet or meters.**
- **Altitude bug**
- **Airspeed indicator (20mph to 350mph), 1mph resolution. Airspeed can be displayed in mph, km/h or knots**
- **Digital and analog VSI indicator. Scale of 1000ft/min, 2000ft/min and 4000ft/min / 5m/s, 10m/s, and 20m/s. Resolution of 1ft/min, 1m/s**
- **Serial Altitude encoder output via the RS232 ports (MGL Avionics CNV-ALT required for parallel gillham code output)**
- **Density altimeter**
- **OAT (Outside Air Temperature) display using an external OAT probe**
- **Supply Voltage display**
- **Stopwatch timer**
- **Automatic / Manual flight timer**
- **RTC (Real Time Clock)**

- Glide ratio indicator
- Barometer (actual local pressure)
- TAS (true airspeed) display
- Built in G-Force meter that can measure g-forces exerted in an aircraft up to +-10g. The XTreme-EFIS also has the facility to record the maximum positive and negative g-forces encountered
- Wind speed and wind direction indication. Note (2)
- Turn Indicator. Note (1)
- Built in Slip/Skid indicator.
- CDI indicator
- Waypoint and Route navigation
- GPS Flight Path (calculated artificial horizon based on GPS information)
- 2-axis Autopilot. Note (5)

## **Engine Monitor:** Note (3)

- 1x Engine RPM
- 1x Rotor RPM
- 1x Manifold pressure
- 1x Oil pressure input
- 1x Oil temperature input
- 2x Auxiliary analog channels (Pressure/Temperature/Current/Generic input)
- 12 Channel EGT / CHT display
- 2x Fuel Flow
- 2x Fuel Level
- Special Rotax 912/914 engine monitor mode utilizing the standard built in Rotax NTC CHT probes
- Programmable maintenance timer for scheduled routine engine maintenance
- Engine display screens are automatically configured to optimize screen space depending on what parameters are been displayed
- User settable Hobbs meter (password protected)
- Fuel range / endurance based on TAS or GPS ground speed
- Supply Voltage display
- Current monitor to measure charge/discharge currents. Note (4)
- Engine leaning feature
- Cruise mode feature

## **ULPower ECU Display**

- Displays engine information from the ULPower ECU (Engine Control Unit) via the RS232 port
- The XTreme-EFIS has a dedicated ULPower ECU display screen
- Displays warning messages from the ULPower ECU
- Supports the ULPower Aux box

## **Rotax 912is**

- The XTreme-EFIS can connect to the Rotax 912iS ECU directly or by using the MGL Avionics RDAC CAN 912iS
- Displays engine information from the Rotax 912iS ECU
- The XTreme-EFIS has dedicated Rotax 912iS display screens
- Displays Engine, Sensor and Device Status messages from the Rotax 912iS ECU

## **General:**

- Alarms on most displays
- Programmable maintenance timer for scheduled routine engine maintenance
- Programmable airframe timer for scheduled airframe maintenance.
- Records maximum and minimum values of most displayed values

- Built in data recorder – records all engine data, GPS data, altitude, airspeed and VSI to the SD card. Data is stored on the SD card in a .csv (Comma Separated Value) file. The recorded data can be imported into a spreadsheet type program or alternatively the data can be viewed using the free XTreme Data Viewer PC program.
- Includes a 100 entry automatic flight log (Records start date&time, flight time, pilot number, Hobbs time, maintenance time, max altitude, airspeed and VSI reached during the flight)
- User configurable start up (Splash) screen
- Unlimited configurable checklists
- Unlimited configurable graphic information displays
- Automatic or manual local magnetic variation
- Dual menu system for quick item selection and user setups
- Sunrise / Sunset calculator
- Firmware upgrades via SD Card
- 1 year limited warranty

- (1) Requires optional MGL Avionics AHRS sensor unit (SP7)
- (2) Requires optional MGL Avionics compass sensor unit (SP6)
- (3) Requires optional MGL Avionics RDAC (Engine monitor) unit
- (4) Requires optional MGL Avionics closed loop current sensor
- (5) Requires optional MGL Avionics servos

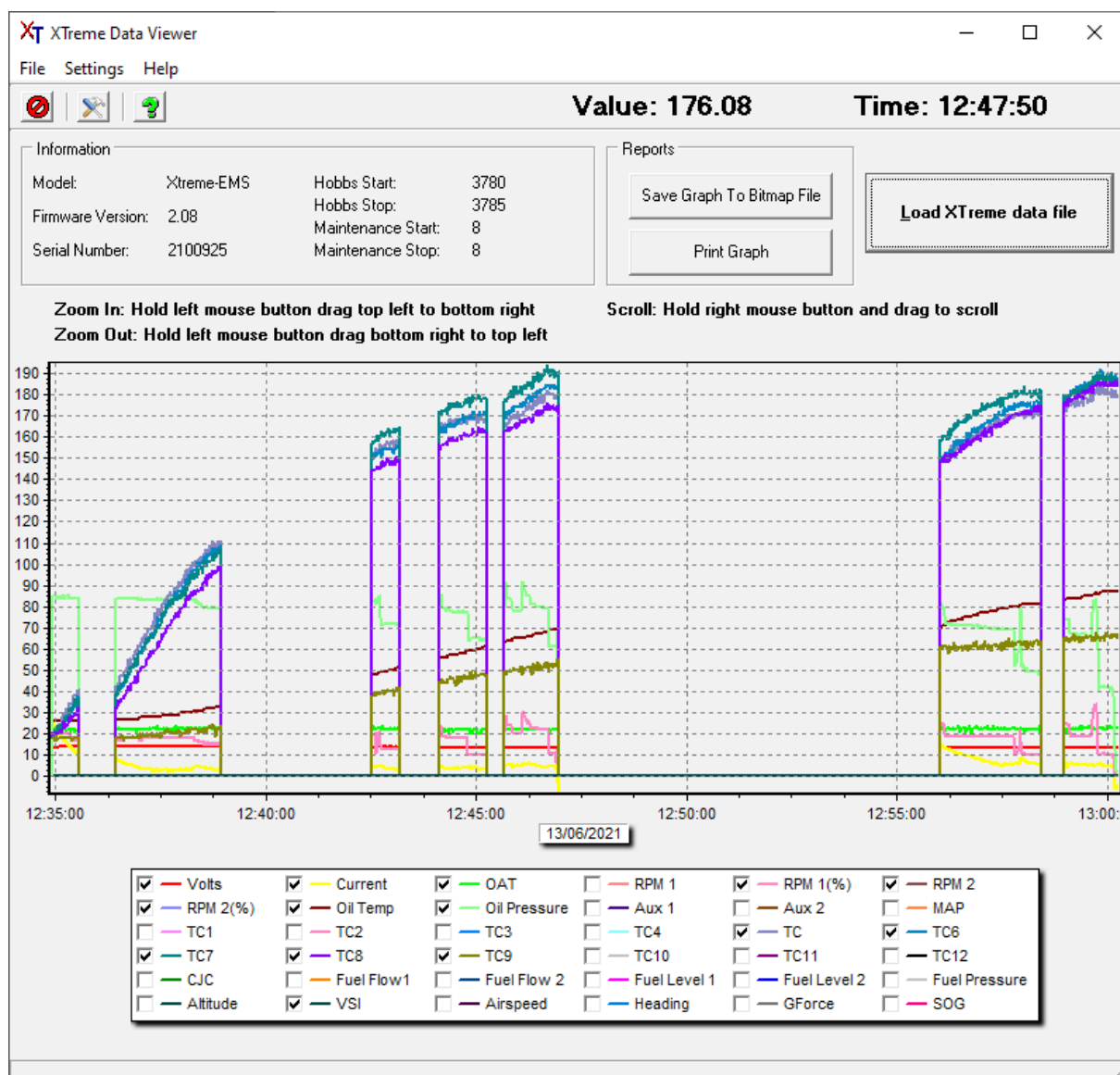

## 2 XTreme-EFIS Layout

### 2.1 Front layout



### 2.2 Rear layout

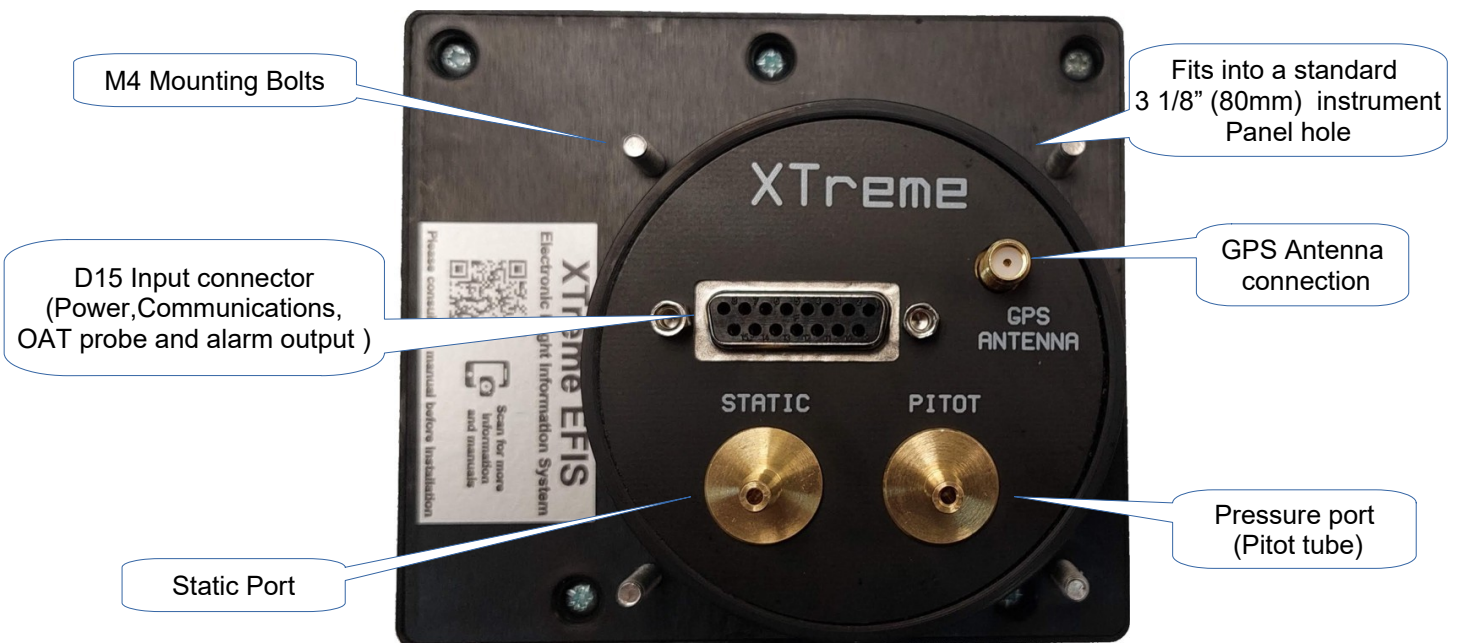

# 3 Display Screens

Press the left or right most soft keys to cycle through the display screens. The display screens can be enabled / disabled in the "DISPLAY SETUP" menu option.

EFIS DISPLAY



EFIS / EMS DISPLAY



EFIS / HSI DISPLAY



VFR DISPLAY



VFR / EMS DISPLAY



EMS DISPLAY

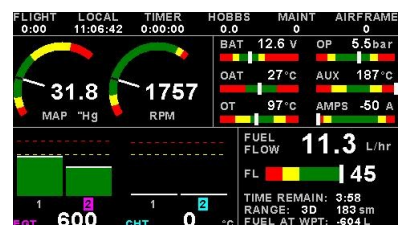

GPS DISPLAY

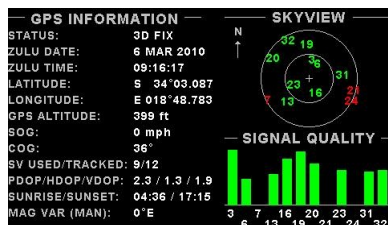

CHECKLIST / INFORMATION DISPLAY

\*\*\*\* SAMPLE CHECKLIST \*\*\*\*  
 NORMAL TEXT FILE WITH .ECL EXTENSION  
 EACH LINE MUST BE TERMINATED IN CR  
 MAXIMUM 60 CHARS PER LINE  
 MAXIMUM 30 LINES PER CHECKLIST FILE

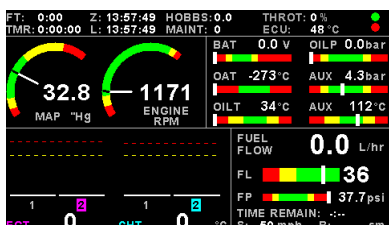

ROTAX ECU FAULTS  
 A: THROTTLE POSITION  
 A: RESERVED  
 A: SENSOR DRIVE VOLTAGE 1  
 B: RESERVED  
 B: RESERVED  
 A: INTERNAL FLASH CRC VERIFICATION  
 A: RESERVED  
 A: MAINTENANCE CAN BUS  
 A: PILOT DISPLAY CAN BUS  
 B: EGT INJECTOR CYLINDER 4  
 B: EGT INJECTOR CYLINDER 3  
 B: EGT INJECTOR CYLINDER 2  
 B: EGT INJECTOR CYLINDER 1

ROTAX ECU STATUS  
 LANE A DATA: NO  
 LANE B DATA: NO  
 ENGINE HOURS: 0.00  
 ECU HOURS: 0.00  
 ENGINE AMBIENT PRESSURE: 0hPa  
 LANE IS NOT IN CONTROL OF GENERATOR  
 POWER MODE  
 LANE IS COMMANDING GENERATOR B  
 WARNING LAMP OFF

**ROTAX**

### 3.1 EFIS display

The EFIS information is displayed in a full screen format.



#### 3.1.1 Heading tape



The heading tape is located at the top of the EFIS screen. The heading bug will be displayed in yellow if it is in the view area else it will turn cyan. The heading bug will always point to the shortest direction to achieve the correct heading. The heading bug can be changed in the quick select menu. The heading is corrected for attitude while pitching and rolling (MGL Avionics AHRS unit required (SP7)). The Compass parameters can be configured in the "COMPASS SETUP" menu. The small magenta triangle indicates coarse over ground from the GPS receiver. The coarse over ground indicator will only be displayed when a valid 2D or 3D GPS fix has been achieved. The heading tape source of information can be from a magnetic sensor (MGL Avionics SP6) or from the coarse over ground value from the GPS receiver. When the heading source of information is from the GPS receiver then the heading will be displayed in magenta.

#### 3.1.2 Ground Speed **GS - - -**

This is located in the top left corner of the EFIS display. The ground speed value will only be displayed when a valid 2D or 3D GPS fix has been achieved.

#### 3.1.3 Local Pressure Settings (QNH) **1013mB**

This is located in the top right corner of the EFIS display. Turn the rotary control to change the local pressure setting. The local pressure can be displayed in mB or in "HG.

#### 3.1.4 True Airspeed (TAS) **TAS 0**

This is located in the bottom left corner of the EFIS display.

What is TAS and how is it calculated?

TAS is indicated airspeed (IAS) compensated for altitude and temperature. Often pilots ignore the effect of temperature and only take altitude into account when converting IAS to TAS. For practical purposes this is quite accurate and gives a good reflection on your true airspeed. Keeping in mind that IAS measurement is subject to errors caused by airflow around your aircraft, there seems little point in taking this calculation to absolute resolution.

Again, we have decided to use a formula often used by pilots. This way the instrument reading will agree with what pilots are used to.

Add 1.75% of IAS per 1000 ft (304.9 m) increase in altitude above sea level.  
We assume here that IAS = RAS (rectified air speed).

### 3.1.5 Airspeed Tape

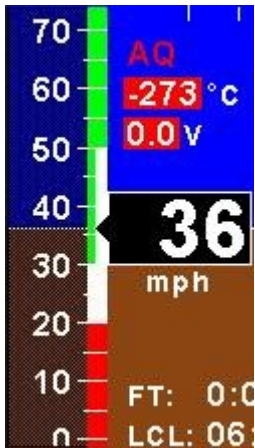

This is located to the left of the EFIS display. The Vso (Min safe speed, landing), Vs1 (Min safe speed, normal), Vfe (Max flap speed), Vno(Max maneuvering speed), Vne (Max exceed speed), Vx (Best angle of climb) and Vy (Best rate of climb) can be configured in the "AIRSPEED SETUP" menu.

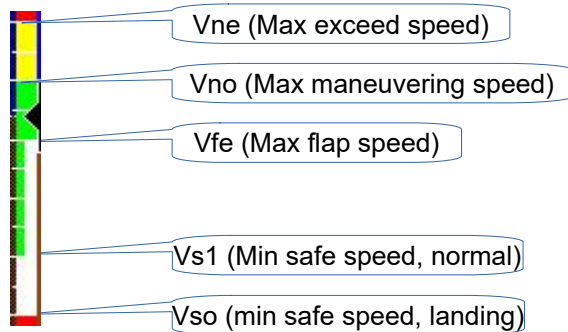

### 3.1.6 Information display area 1



The 1<sup>st</sup> line is the GPS fix status. AQ=Acquiring (Red text color), 2D=2D fix, 3D=3D fix.  
 The 2<sup>nd</sup> line is the OAT value. Outside air temperature can be measured using the external temperature probe. The OAT parameters can be configured in the "OAT SETUP" menu.  
 The 3<sup>rd</sup> line is the supply voltage value. The XTreme-EFIS can measure the supply voltage up to 30Vdc. The supply voltage parameters can be configured in the "VOLTS SETUP" menu.  
 The 4<sup>th</sup> line is the short name of the currently selected active waypoint.

### 3.1.7 Altitude Tape



This is located to the right of the EFIS display. The altitude bug will be displayed in yellow if it is in the view area else it will turn cyan in color. The altitude bug can be changed in the quick select menu. The altitude parameters can be configured in the "ALTITUDE SETUP" menu.

### 3.1.8 VSI displays

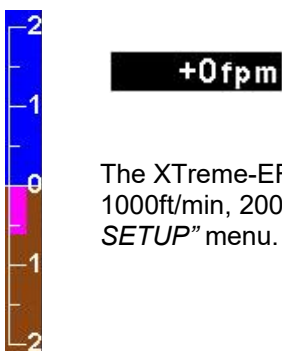

The XTreme-EFIS provides an analog VSI as well as a digital readout. The VSI scale can be set for a scale of 1000ft/min, 2000ft/min or 4000ft/min / 5m/s, 10m/s, or 20m/s. The VSI parameters can be configured in the "VSI SETUP" menu.



3.1.9 Information display area 2



The 1st line is the density altitude value. Density altitude is a perceived altitude that pertains to your current altitude and temperature (and to a lesser extent on your current moisture content of the air). Density altitude is relevant for performance calculations of your aircraft. Density altitude affects the performance of your engine, propeller and airfoils. The most noticeable affects of density altitude are length of take-off and landing runs and the ability of your aircraft to carry weight. There are several methods to calculate density altitude, all result in readings that are very close to each other. We decided to implement a popular formula that is often used by pilots to calculate density altitude at their location.

T=Ambient temperature in degrees C  
 Ts=15-.0019812\*Pressure Altitude(ft)

Density Altitude=Pressure Altitude(ft)+118.6\*(T-Ts)

The 2<sup>nd</sup> line is the G-Force value.

3.1.10 Timer area

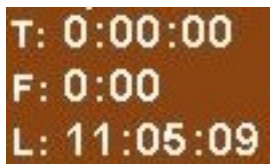

The 1<sup>st</sup> line is the timer. The Timer can be configured in the quick select menus.  
 The 2<sup>nd</sup> line is the flight timer. The flight time is automatically reset to zero when a new flight is started (manual or automatic flight detection). The flight timer can be started in the quick select menu (Manual selection).  
 The 3<sup>rd</sup> line is the local time. Local time normally includes an offset from UTC time. The UTC offset can be set in the "TIMERS SETUP" menu.

3.1.11 Slip / Skid indicator



This is located at the bottom of the display. The source of information for this indicator is derived from the accelerometer aligned with the pitch axis of the aircraft, i.e. the acceleration forces acting in the direction of the wings. The slip / skid ball can be enabled / disabled in the "HORIZON SETUP" menu

3.1.12 Turn indicator



This is located under the compass tape. The left and right notches indicate a (correctly balanced) rate 1 turn (3° per second). Therefore 180° turn will take 1 minute, 360° turn will take 2 minutes. The turn indicator can be enabled / disabled in the "HORIZON SETUP" menu

3.1.13 Horizon line, Roll and Pitch indicators

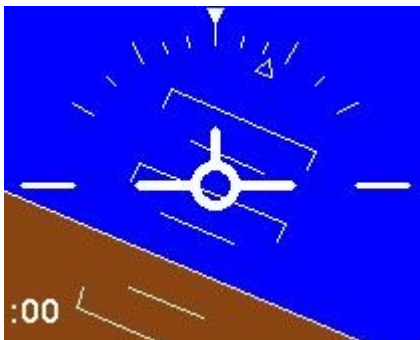

The horizon line separates the ground from the sky just like a conventional gyro based artificial horizon. The ground color can be selected to be shown in green

The roll markers have tick marks at 10, 20, 30, 45, 60 and 90 degrees of roll.

The pitch markers are horizontal with the horizon and are equally spaced with 5 degrees of separation between lines. The 10 degree pitch lines have a small end which points towards the horizon.

The bank indicator can be configured for a moving type or a stationary type.

All the above parameters can be configured in the "HORIZON SETUP" menu.

### 3.1.14 Wind speed and direction



The XTreme-EFIS has the ability to calculate and display the wind speed and direction.

The following variables must be available in order to calculate the wind speed and wind direction

-A valid 2D or 3D GPS fix (COG/SOG)

-Magnetic heading (MGL Avionics magnetic compass is required (SP2/SP6))

-TAS

The wind speed and direction will only be displayed if a valid 2D or 3D GPS fix has not been achieved. The wind speed and direction will display incorrect information when not in a straight and level flight.

### 3.1.15 CDI Indicator



The CDI indicator will be displayed at the bottom of the EFIS display when the pilot has selected an active waypoint to fly to. The CDI bar moves off the center to indicate which direction you must fly in order to stay on the original course. If the CDI is to the left then fly left until the CDI Bar is in the center of the “tick” markers. The “tick” marker scale can be setup in the “*GPS SETUP*” menu.

### 3.2 EFIS Quick Select Menu System



Press the rotary control when the EFIS screen is displayed to access the EFIS quick select menu.

#### MARK WAYPOINT:



Select this menu option to mark a waypoint. The latitude, longitude and altitude are automatically set based on the current location. Enter a short name and long name for the waypoint so you can easily identify it. Press save once you have finished editing and to save the waypoint to the waypoint.ewd file.

#### START FLIGHT:

Select this option to manually start / stop a flight. This menu option is only shown if the XTreme-EFIS is setup to select the manual flight option under the "FLIGHT LOG" setup menu. The flight timer ":" will flash to indicate that a valid flight is in progress.

#### REALIGN AHRS:



If the following message appears then you have to realign the AHRS. This is due to excessive maneuvering or exceeding the maximum bank, pitch or yaw rates. Select this function to indicated to the instrument that you are flying straight and level and that gravity tracking may be accelerated to ensure rapid realignment of the horizon.

#### LEVEL PITCH:

You can level the pitch of the artificial horizon should your aircraft fly "nose up" or "nose down" due to trim.

#### ALTITUDE BUG:

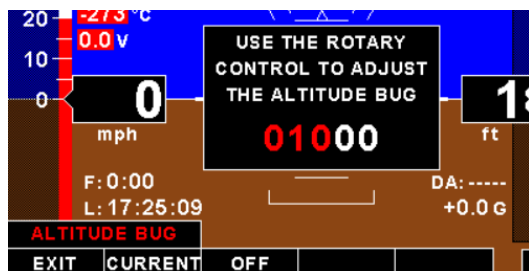

Use the rotary control to adjust the altitude bug. Press the "ON/OFF" soft key to enable or disable the altitude bug. Select "CURRENT" to set the altitude bug to the current altitude. Press the rotary control to adjust the altitude bug by 500. Press the rotary control in to adjust it by 50.

**HEADING BUG:**

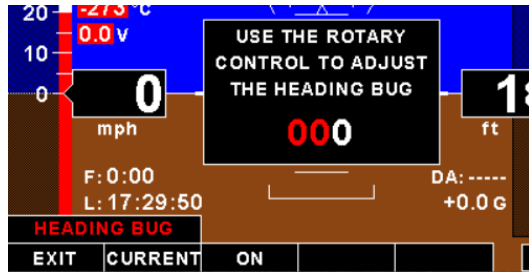

Use the rotary control to adjust the heading bug. Press the “ON/OFF” soft key to enable or disable the heading bug. Select “CURRENT” to set the heading bug to the current heading. Press the rotary control to adjust the heading bug by 10 degrees. Press the rotary control in to adjust it by 1 degree.

**TIMER:**

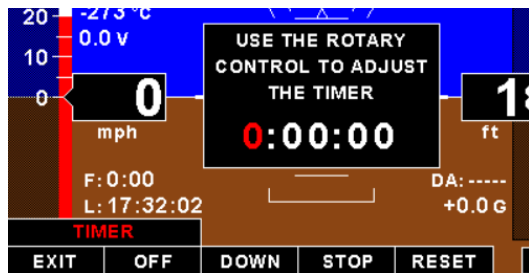

Select this menu option to configure the timer. Use the rotary control to adjust the timers reset value. Press the “UP/DOWN” soft key to select whether the timer must count up or down, the “START/STOP” soft key to start or stop the timer and the “ON/OFF” soft key to enable or disable the timer.

**MIN/MAX:**

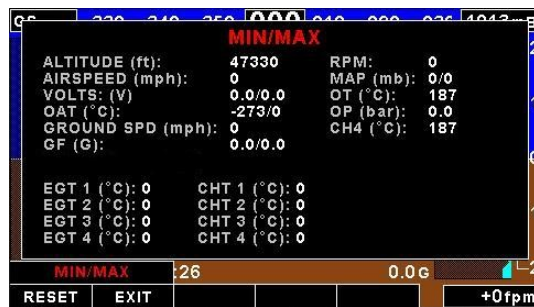

Select this menu option to display the maximum and minimum captured values. Press the “RESET” soft key to reset the min/max values to the current values.

**BACKLIGHT:**



Select this menu option to adjust the backlight brightness level. This may be desirable during low light flying conditions. Use the rotary control to adjust the brightness level.

**MENU:**

Select this menu option to enter the main menu system.

### 3.3 AHRS Failure

The EFIS display will have the following indicators crossed out in case of a AHRS failure.

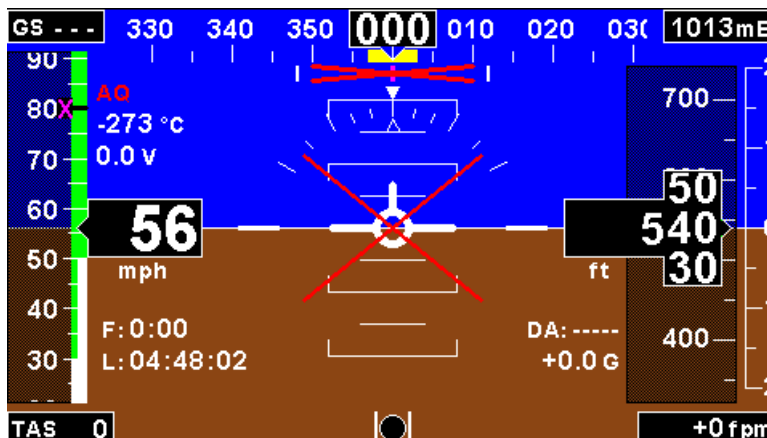

### 3.4 EFIS / EMS Display

The EFIS / EMS displays the EFIS in a 2/3 screen format and the engine data in a 1/3 screen format.



#### 3.4.1 EFIS Display

The 2/3 EFIS display is in the same layout format as the full EFIS display. Please see the section 3.1 for more information.

#### 3.4.2 RPM / Rotor / MAP display section

The RPM / Rotor / MAP section will maximize the space according to which parameter is enabled. The RPM, Rotor and MAP parameters can be configured in the "EMS SETUP" menu.



RPM, Rotor and MAP enabled.



RPM and MAP enabled.



RPM only.



MAP only.

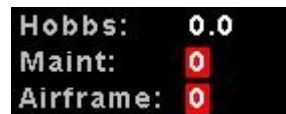

If the RPM, Rotor and MAP displays are disabled then the Hobbs, maintenance and airframe timers will be shown.

#### 3.4.3 Oil Temperature, Oil Pressure, Current and Auxiliary analog display section



This section displays the oil temperature, oil pressure, as well as the 2 auxiliary analog channels (display labels are configurable). If more then 2 channels are enabled then the display area will alternate at a 3 second interval. The oil temperature/pressure as well as the 2 auxiliary analog channels can be configured in the “EMS SETUP” menu.

**3.4.4 Fuel display section**

The XTreme-EFIS supports dual fuel flow and dual fuel levels. The fuel section will automatically try and maximize the display area according to the fuel parameters selected. The XTreme-EFIS has 20 different fuel modes of operation. The fuel parameters can be configured in the “FUEL SETUP” menu.

**3.4.4.1 Single fuel flow and calculated tank level (single tank)**

- Single fuel flow and fuel level sender (single tank)
- Differential fuel flow and calculated tank level (single tank)
- Differential fuel flow and fuel level sender (single tank)
- Summed fuel flow and calculated tank level (single tank)
- Summed fuel flow and fuel level sender (single tank)



**3.4.4.2 Dual fuel flow and calculated tank levels (dual tank)**  
 Dual fuel flow and dual fuel level senders (dual tank)

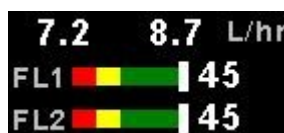

**3.4.4.3 Single fuel flow and dual fuel level senders (dual tank)**

- Single fuel flow, single fuel level sender, single calculated tank
- Differential fuel flow and dual fuel level senders (dual tank)
- Differential flow, single fuel level sender, single calculated tank
- Summed fuel flow and dual fuel level senders (dual tank)
- Summed fuel flow, single fuel level sender, single calculated tank



**Single / Differential / Summed fuel flow, single fuel level sender, single calculated tank**

These modes are nice for multiple fuel tanks whereby one or more tanks are difficult to insert level senders in. Potential problems such as those listed below can easily be diagnosed by doing side by side comparisons between a calculated and physical tank.

- Leaks in the fuel system
- Uneven drain of interconnected tanks
- Malfunction of the level sender
- Malfunction of the flow sender

### 3.4.4.5 Single fuel flow only indicator

This mode is displayed if either fuel flow 1 or fuel flow 2 is selected and no fuel level senders are selected.



### 3.4.4.6 Dual fuel flow indicator

This mode is displayed if both fuel flow 1 and fuel flow 2 are selected and the fuel mode is selected for dual flow. Both fuel level senders are disabled.

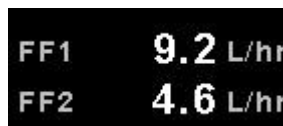

### 3.4.4.7 Single tank level indicator

This mode is displayed if either fuel level 1 or fuel level 2 is selected. Both fuel flow senders are disabled.



### 3.4.4.8 Dual tank level indicator

This mode is displayed if both fuel level 1 and fuel level 2 are selected. Both fuel flow senders are disabled.



### 3.4.4.9 Differential / Summed fuel flow

This mode is displayed if both fuel flow 1 and fuel flow 2 are selected and the fuel mode is selected for either differential or summed.



## 3.4.5 EGT / CHT display section



The XTreme-EFIS supports up to 12 thermocouples for EGTs/CHTs. The EGT/CHT section will automatically try and maximize the display area according to the number of EGTs/CHTs selected. The EGT/CHT parameters can be configured in the "EGT SETUP" and "CHT SETUP" menu.



The EGT/CHT number will highlight to the indicated temperature value if "HIGHEST" is selected. The EGT highlight color is magenta, and the CHT color is cyan.

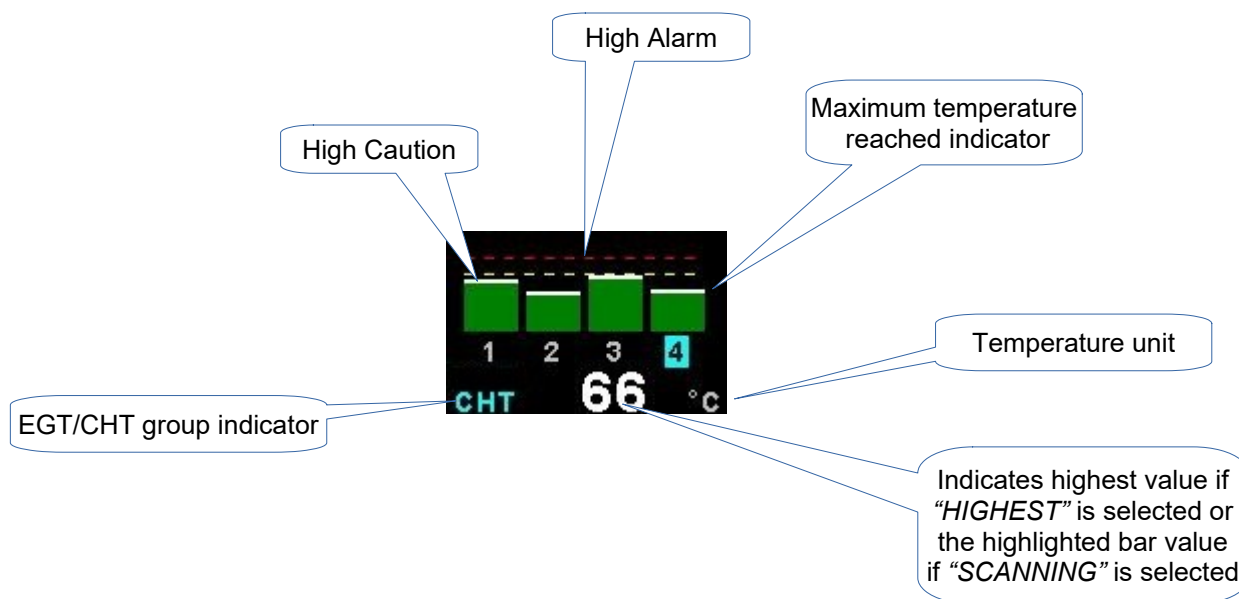

### 3.5 EFIS/EMS Quick Select Menu System



Press the rotary control when the EFIS / EMS screen is displayed to access the quick select menu.

**MARK WAYPOINT:**

See section 3.2 for more information.

**START FLIGHT:**

See section 3.2 for more information.

**REALIGN AHRS:**

See section 3.2 for more information.

**LEVEL PITCH:**

See section 3.2 for more information.

**ALTITUDE BUG:**

See section 3.2 for more information.

**HEADING BUG:**

See section 3.2 for more information.

**FUEL REFILL:**

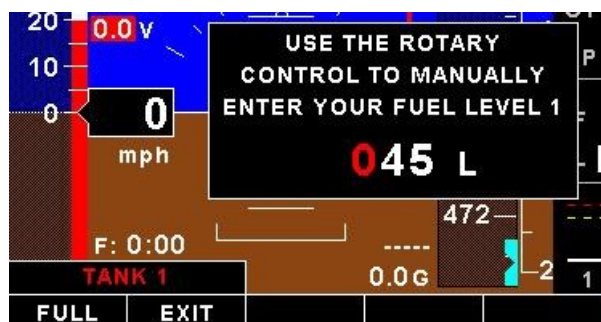

Select this menu option to refill a calculated fuel tank. Press the "FULL" soft key for a quick fill to the full reading in the tank setup menu. Press the "EXIT" soft key when done.

**FUEL TOTALS:**

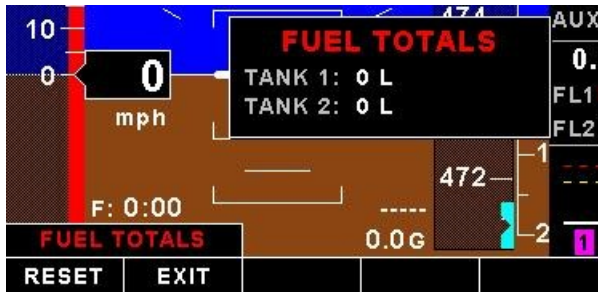

Select this menu option to display the fuel totals. Press the “RESET” soft key to reset the totalisers to zero. Press the “EXIT” soft key when done.

**TIMER:**

See section 3.2 for more information.

**MIN/MAX:**

See section 3.2 for more information.

**BACKLIGHT:**

See section 3.2 for more information.

**MENU:**

Select this menu option to enter the main menu system.

### 3.6 EFIS / HSI Display

The EFIS/HSI displays the EFIS in a 2/3 screen format and the navigation information in a 1/3 screen format.



#### 3.6.1 EFIS Display

The 2/3 EFIS display is in the same layout format as the full EFIS display. Please see the section 3.1 for more information.

#### 3.6.2 Navigation Display

The XTreme-EFIS displays the navigation information in a form of a HSI (Horizontal Situation Indicator)

##### Heading:

The yellow bar at the top points to your heading. It is also known as the lubber line.

##### Compass Rose:

The compass rose is the 360 degree circle around the HSI. It is broken down into 5 degree divisions.

##### Heading Bug:

The 2 yellow lines indicate the heading bug. The heading bug can be adjusted in the quick select menu system.

##### Coarse Selector:

The magenta arrow (Indicating that the information is coming the internal GPS) points in the direction which you must fly in order to reach the active waypoint.

##### CDI (Coarse Deviation Indicator):

The center line of the Coarse Selector moves off the center to indicate which direction you must fly in order to stay on the the original coarse. If the CDI is to the left then fly left until the CDI lines up with the Coarse selector. The "tick" marker scale can be setup in the "GPS SETUP" menu.

##### Navigation Information:

Under the HIS you will find the short name of the active waypoint. You will also find the following information:

**ETA:** Estimated Time of Arrival.

**ETE:** Estimated Time En Route.

**TRK:** GPS ground track.

**DTW:** Distance to waypoint.

**CRS:** The current set coarse to the active waypoint.



## 3.7 EFIS / HSI Quick Select Menu System

**EXIT**  
**MARK WAYPT**  
**START FLIGHT**  
**REALIGN AHRS**  
**LEVEL PITCH**  
**ALTITUDE BUG**  
**HEADING BUG**  
**TIMER**  
**MIN/MAX**  
**BACKLIGHT**  
**MENU**

Press the rotary control when the EFIS / HSI screen is displayed to access the quick select menu.

### ***MARK WAYPOINT:***

See section 3.2 for more information.

### ***START FLIGHT:***

See section 3.2 for more information.

### ***REALIGN AHRS:***

See section 3.2 for more information.

### ***LEVEL PITCH:***

See section 3.2 for more information.

### ***ALTITUDE BUG:***

See section 3.2 for more information.

### ***HEADING BUG:***

See section 3.2 for more information.

### ***TIMER:***

See section 3.2 for more information.

### ***MIN/MAX:***

See section 3.2 for more information.

### ***BACKLIGHT:***

See section 3.2 for more information.

### ***MENU:***

Select this menu option to enter the main menu system.

### 3.8 VFR Display

The VFR display shows the altitude, airspeed, VSI, G-Force, slip and navigation in a full screen format.



#### 3.8.1 Airspeed Dial



This displays the airspeed as a traditional analog airspeed indicator. A digital readout of the airspeed value is also displayed below the dial. The  $V_{SO}$  (min safe speed, landing),  $V_{S1}$  (min safe speed, normal),  $V_{FE}$  (max flap speed),  $V_{NO}$  (max maneuvering speed) and  $V_{NE}$  (max exceed speed) can be configured in the “AIRSPEED SETUP” menu.

#### 3.8.2 Altitude Dial



This displays the altitude as a traditional 3 needle analog altimeter. A digital readout of the altitude value is also displayed below the dial. The altitude parameters can be configured in the “ALTITUDE SETUP” menu.

The local pressure setting (QNH) is located in the bottom center of the altitude dial. Turn the rotary control to change the local pressure setting. The local pressure can be displayed in mB or in “HG.”

#### 3.8.3 VSI indicator

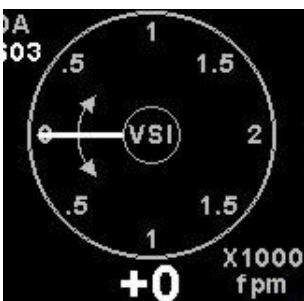

This displays the VSI as a traditional VSI indicator. The scale and units can be configured in the “VSI SETUP” menu.

GS  
46

### 3.8.4 Ground Speed

This is located in the top left corner of the VFR display. The ground speed value will only be displayed when a valid 2D or 3D GPS fix has been achieved.

TAS  
67

### 3.8.5 True Airspeed (TAS)

Please see section 3.1.4 for more information.

AQ

### 3.8.6 GPS Fix Status

GPS fix status. AQ=acquiring (Red text color), 2D=2D fix, 3D=3D fix.

DA  
2588

### 3.8.7 Density Altitude

Please see section 3.1.9 for more information.

11  
←

### 3.8.8 Wind speed and Direction

Please see section 3.1.14 for more information.

014

### 3.8.9 Heading Box

The heading is corrected for attitude while pitching and rolling (MGL Avionics AHRS unit required (SP7)). The Compass parameters can be configured in the "COMPASS SETUP" menu. The heading source of information can be from a magnetic sensor (MGL Avionics SP6) or from the coarse over ground value from the GPS receiver. When the heading source of information is from the GPS receiver then the heading will be displayed in magenta.

### 3.8.10 Information display area 1

```
Flight Time: 0:00
Zulu Time: 00:00:00
Local Time: 17:14:21
Timer: 0:00:00
Hobbs: 0.0
Maintenance: 0
Airframe: 0
```

#### **Flight Time:**

The flight time is automatically reset to zero when a new flight is started (manual or automatic flight detection). The text “.” will flash when a flight is active. The flight timer can be started in the quick select menu (Manual flight mode).

#### **Zulu Time:**

This is also known as UTC or GMT time. The RTC (real time clock) can be selected to either use the internal RTC or from the GPS (external or internal). The RTC can be setup in the "TIMERS SETUP" menu.

#### **Local Time:**

Local time normally includes an offset from Zulu time. The local offset can be set in the "TIMERS SETUP" menu.

**Timer:**

The Timer can be configured in the quick select menu.

**Hobbs:**

The XTreme-EFIS contains a password protected Hobbs timer. The Hobbs time can be set to the current known engine time in the "TIMERS SETUP" menu. The Hobbs timer will only increment when the RPM is greater then the "HOBBS MINIMUM RPM".

**Maintenance:**

This timer is set in engine hours and it will count down to zero when the engine RPM is greater then the "HOBBS MINIMUM RPM" value as set in the "TIMERS SETUP". A good use for this function is to set the hours until your next spark plug change or engine inspection.

The purpose of this function is to assist you in determining remaining hours until maintenance will be required. It is not intended as a replacement for the aircraft's maintenance log. It is therefore important that the aircraft's maintenance log be maintained in the normal manner. You should further use your own discretion in performing maintenance earlier than indicated should any aircraft performance problems arise.



A maximum of 999 hours can be entered as a maintenance interval. A reminder message will appear on startup when zero hours are remaining. The reminder message will automatically disappear after 10 seconds or if the pilot presses any key. Engine running time for the

purpose of the maintenance timer is defined as the run time where the engine RPM is greater than the "HOBBS MINIMUM RPM" value as set in the "TIMERS SETUP".

**Airframe:**

This timer operates similar to the engine maintenance timer but is based on flight time. You might use it to schedule thorough airframe checks at intervals..



A reminder message will appear on startup when zero hours are remaining. The reminder message will automatically disappear after 10 seconds or if the pilot presses any key.

**3.8.11 Information area 2**



**Volts:**

The XTreme-EFIS can measure the supply voltage up to 30Vdc. The supply volts parameters can be configured in the "VOLTS SETUP" menu.

**OAT:**

Outside air temperature can be measured using the external temperature probe. The OAT parameters can be configured in the "OAT SETUP" menu.

**Glide Ratio:**

Glide ratio can be measured up to 1:99. Glide ratio is measured as a ratio between forward movement of the aircraft vs. vertical sink rate. Please note that the forward movement of the aircraft is not synonymous with horizontal forward movement relative to the earth surface but is a function of airspeed.



**Barometer:**

Ambient pressure can be displayed in either millibar (mb) or in Inches of Mercury (“Hg”). The setup for the “PRESSURE UNIT” in the “ALTITUDE SETUP” menu will determine which.

**Aircraft Reg:**

The aircraft registration is displayed here.

**3.8.12 Slip indicator**



The source of information for this indicator is derived from the accelerometer aligned with the pitch axis of the aircraft, i.e. the acceleration forces acting in the direction of the wings. The slip/skid ball can be enabled/disabled in the “HORIZON SETUP” menu

**3.8.13 Information display area 3**

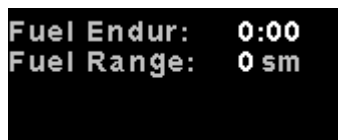

**Fuel Endur:**

This displays the time remaining with the current fuel.

**Fuel Range:**

This displays the aircraft range based on the speed and fuel remaining of the aircraft.

**3.8.14 Navigation Display**



Please see section 3.6.2 for more information.

3.8.15 G-Force Page

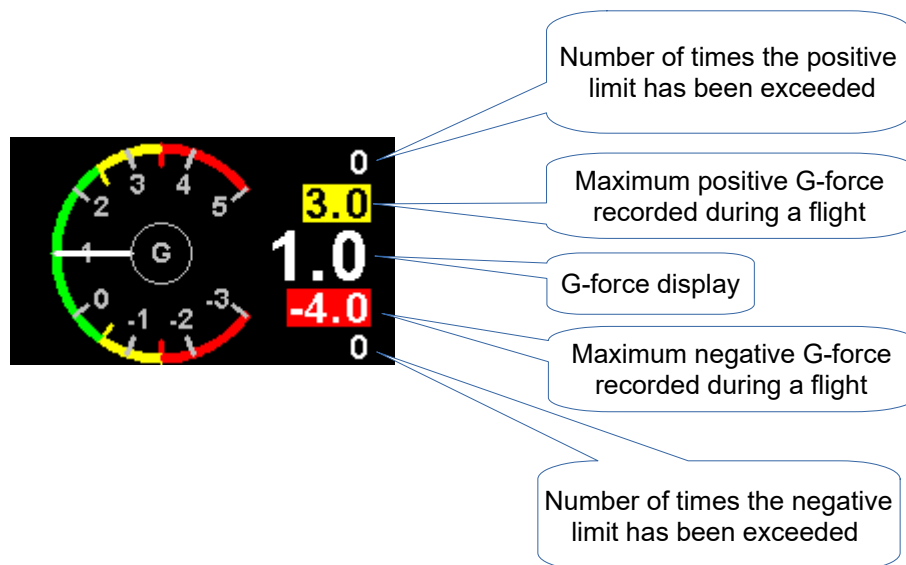

## 3.9 VFR Quick Select Menu System



**EXIT**  
MARK WAYPT  
START FLIGHT  
HEADING BUG  
TIMER  
MIN/MAX  
BACKLIGHT  
MENU

Press the rotary control when the VFR display screen is displayed to access the quick select menu.

### ***MARK WAYPOINT:***

See section 3.2 for more information.

### ***START FLIGHT:***

See section 3.2 for more information.

### ***HEADING BUG:***

See section 3.2 for more information.

### ***TIMER:***

See section 3.2 for more information.

### ***MIN/MAX:***

See section 3.2 for more information.

### ***BACKLIGHT:***

See section 3.2 for more information.

### ***MENU:***

Select this menu option to enter the main menu system.

### 3.10 VFR / EMS Display

The VFR display shows the altitude, airspeed and VSI in the traditional round gauges with 1/3 of the screen reserved for engine data.



#### 3.10.1 Airspeed Dial



This displays the airspeed as a traditional analog airspeed indicator. A digital readout of the airspeed value is also displayed below the dial. The  $V_{so}$  (min safe speed, landing),  $V_{s1}$  (min safe speed, normal),  $V_{fe}$  (max flap speed),  $V_{no}$  (max maneuvering speed) and  $V_{ne}$  (max exceed speed) can be configured in the "AIRSPEED SETUP" menu.

#### 3.10.2 Altitude Dial



This displays the altitude as a traditional 3 needle analog altimeter. A digital readout of the altitude value is also displayed below the dial. The altitude parameters can be configured in the "ALTITUDE SETUP" menu.

The local pressure setting (QNH) is located in the bottom center of the altitude dial. Turn the rotary control to change the local pressure setting. The local pressure can be displayed in mB or in "HG.

#### 3.10.3 VSI indicator



This displays the VSI as a traditional VSI indicator. The scale and units can be configured in the "VSI SETUP" menu.

### 3.10.4 Slip indicator



The source of information for this indicator is derived from the accelerometer aligned with the pitch axis of the aircraft, i.e. the acceleration forces acting in the direction of the wings. The slip/skid ball can be enabled/disabled in the “*HORIZON SETUP*” menu

### 3.10.5 Ground Speed

This is located in the top left corner of the VFR display. The ground speed value will only be displayed when a valid 2D or 3D GPS fix has been achieved.

### 3.10.6 True Airspeed (TAS)

Please see section 3.1.4 for more information.

### 3.10.7 GPS Fix Status

GPS fix status. AQ=acquiring (Red text color), 2D=2D fix, 3D=3D fix.

### 3.10.8 Density Altitude

Please see section 3.1.9 for more information.

### 3.10.9 Wind speed and Direction

Please see section 3.1.14 for more information.

### 3.10.10 Heading Box

The heading is corrected for attitude while pitching and rolling (MGL Avionics AHRS unit required (SP7)). The Compass parameters can be configured in the “*COMPASS SETUP*” menu. The heading source of information can be from a magnetic sensor (MGL Avionics SP6) or from the coarse over ground value from the GPS receiver. When the heading source of information is from the GPS receiver then the heading will be displayed in magenta.

### 3.10.11 Information display area 1

Flight Time:	0:00
Zulu Time:	00:00:00
Local Time:	17:14:21
Timer:	0:00:00
Hobbs:	0.0
Maintenance:	0
Airframe:	0

#### **Flight Time:**

The flight time is automatically reset to zero when a new flight is started (manual or automatic flight detection). The text “.” will flash when a flight is active. The flight timer can be started in the quick select menu (Manual flight mode).

**Zulu Time:**

This is also know as UTC or GMT time. The RTC (real time clock) can be selected to come from the internal RTC or from the GPS (external or internal). The RTC can be setup in the “*TIMERS SETUP*” menu.

**Local Time:**

Local time normally includes an offset from Zulu time. The local offset can be set in the “*TIMERS SETUP*” menu.

**Timer:**

The Timer can be configured in the quick select menu.

**Hobbs:**

The XTreme-EFIS contains a password protected Hobbs timer. The Hobbs time can be set to the current known engine time in the “*TIMERS SETUP*” menu. The Hobbs timer will only increment when the RPM is greater then the “*HOBBS MINIMUM RPM*”.

**Maintenance:**

This timer is set in engine hours and it will count down to zero when the engine RPM is greater then the “*HOBBS MINIMUM RPM*” value as set in the “*TIMERS SETUP*”. A good use for this function is to set the hours until your next spark plug change or engine inspection.

The purpose of this function is to assist you in determining remaining hours until maintenance will be required. It is not intended as a replacement for the aircraft's maintenance log. It is therefore important that the aircraft's maintenance log be maintained in the normal manner. You should further use your own discretion in performing maintenance earlier than indicated should any aircraft performance problems arise.

**MAINTENANCE TIMER HAS EXPIRED**

A maximum of 999 hours can be entered as a maintenance interval. A reminder message will appear on startup when zero hours are remaining. The reminder message will automatically disappear after 10 seconds or if the pilot presses any key. Engine running time for the

purpose of the maintenance timer is defined as the run time where the engine RPM is greater than the “*HOBBS MINIMUM RPM*” value as set in the “*TIMERS SETUP*”.

**Airframe:**

This timer operates similar to the engine maintenance timer but is based on flight time. You might use it to schedule thorough airframe checks at intervals, perhaps every 25 or 50 hours.

**AIRFRAME TIMER HAS EXPIRED**

A reminder message will appear on startup when zero hours are remaining. The reminder message will automatically disappear after 10 seconds or if the pilot presses any key.

**3.10.12 Information area 2**



**Volts:**

The XTreme-EFIS can measure the supply voltage up to 30Vdc. The supply volts parameters can be configured in the “*VOLTS SETUP*” menu.

**OAT:**

Outside air temperature can be measured using the external temperature probe. The OAT parameters can be configured in the “OAT SETUP” menu.

**Glide Ratio:**

Glide ratio can be measured up to 1:99. Glide ratio is measured as a ratio between forward movement of the aircraft vs. vertical sink rate. Please note that the forward movement of the aircraft is not synonymous with horizontal forward movement relative to the earth surface but is a function of airspeed.

**Barometer:**

Ambient pressure can be displayed in either millibar (mb) or in Inches of Mercury (“Hg). The setup for the “PRESSURE UNIT” in the “ALTITUDE SETUP” menu will determine which.

**Aircraft Reg:**

The aircraft registration is displayed here.

**3.10.13 Information display area 3**

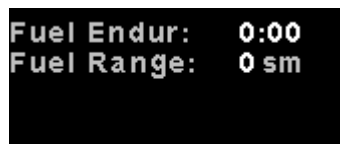

**Fuel Endur:**

This displays the time remaining with the current fuel.

**Fuel Range:**

This displays the aircraft range based on the speed and fuel remaining of the aircraft.

**3.10.14 Navigation Page**



Please see section 3.6.2 for more information.

3.10.15 G-Force Page

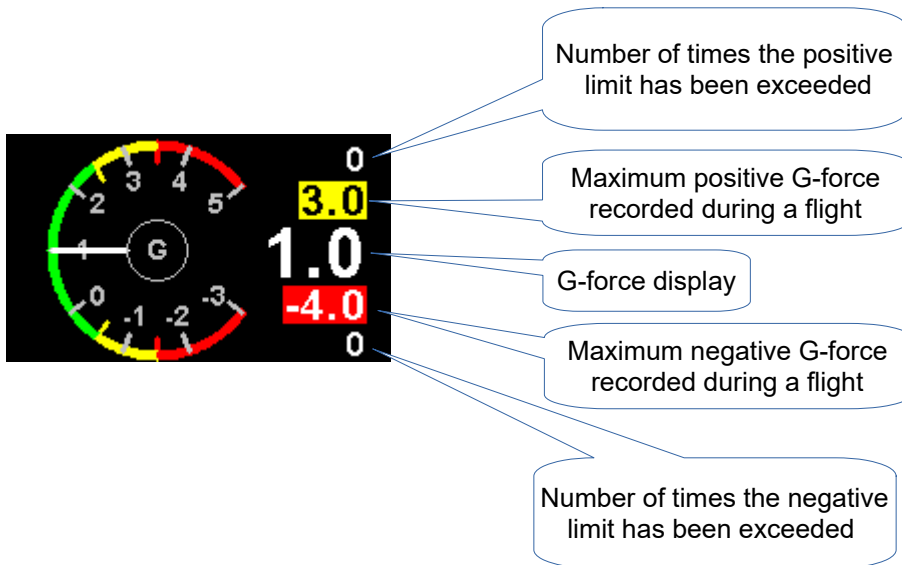



## 3.11 VFR / EMS Quick Select Menu System

**EXIT**

**MARK WAYPT  
START FLIGHT  
HEADING BUG  
FUEL REFILL  
FUEL TOTALS  
TIMER  
MIN/MAX  
BACKLIGHT  
MENU**

Press the rotary control when the VFR screen is displayed to access the VFR quick select menu.

### ***MARK WAYPOINT:***

See section 3.2 for more information.

### ***START FLIGHT:***

See section 3.2 for more information.

### ***HEADING BUG:***

See section 3.2 for more information.

### ***FUEL REFILL:***

See section 3.5 for more information.

### ***FUEL TOTALS:***

See section 3.5 for more information.

### ***TIMER:***

See section 3.2 for more information.

### ***MIN/MAX:***

See section 3.2 for more information.

### ***BACKLIGHT:***

See section 3.2 for more information.

### ***MENU:***

Select this menu option to enter the main menu system.

### 3.12 EMS Display

The engine data is displayed in a full screen format.

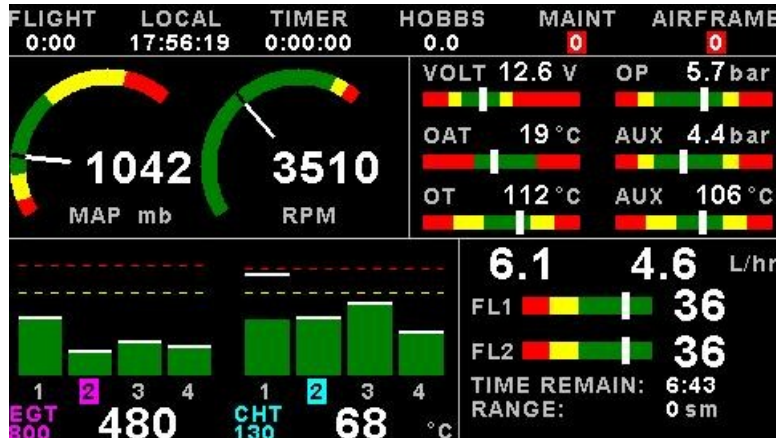

#### 3.12.1 Information bar



##### FLIGHT:

The flight time is automatically reset to zero when a new flight is started (manual or automatic flight detection). The text “.” will flash when a flight is active. The flight timer can be started in the quick select menu (Manual flight mode).

##### LOCAL:

Local time normally includes an offset from Zulu time. The local offset can be set in the “TIMERS SETUP” menu.

##### TIMER:

See section 3.2 for more information.

##### HOBBS:

See section 3.8.10 for more information.

##### MAINT:

See section 3.8.10 for more information.

##### AIRFRAME:

See section 3.8.10 for more information.

#### 3.12.2 RPM / Rotor / MAP display section

The RPM / Rotor / MAP section will maximize the space according to which parameter RPM / Rotor / MAP is enabled. The RPM, Rotor and MAP parameters can be configured in the “EMS SETUP” menu.



RPM 1, RPM 2 and MAP enabled.

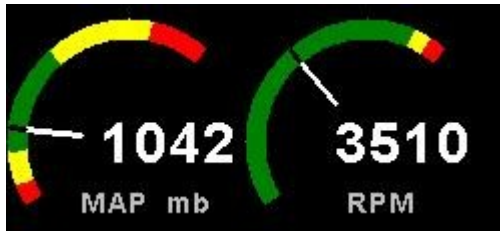

RPM and MAP enabled.



RPM only enabled



MAP only enabled

### 3.12.3 Magneto Check Function

Activate the magneto check function in the sub-menu once you have reached your normal run-up RPM. The display will show the RPM deviation from when the magneto function was activated. Any RPM drops will be displayed as a negative RPM value, a positive reading indicates an increase in RPM.



Switch the mag to left or right. The RPM should display a negative (drop in) RPM. Then switch the mags to "Both". The RPM reading should go back to zero or near zero. A problem should show up as an excessive drop in one mag and the return to zero or close to zero incorrectly.

The RPM display will return to the normal display after 60 seconds.

### 3.12.4 Volts, OAT, Oil Temperature/Pressure, Current and Auxiliary Analog section



This section displays the supply voltage, OAT, oil temperature, oil pressure, as well as the 2 auxiliary analog channels. The oil temperature/pressure as well as the 2 auxiliary analog channels can be configured in the "EMS SETUP" menu.

**3.12.5 Fuel display section**

The XTreme-EFIS supports dual fuel flow and dual fuel levels. The fuel section will automatically try and maximize the display area according to the fuel parameters selected. The XTreme-EFIS has 20 different fuel modes of operation. The fuel parameters can be configured in the "FUEL SETUP" menu. See section 0.0 for more information.

**3.12.5.1 Single fuel flow and calculated tank level (single tank)**

- Single fuel flow and fuel level sender (single tank)
- Differential fuel flow and calculated tank level (single tank)
- Differential fuel flow and fuel level sender (single tank)
- Summed fuel flow and calculated tank level (single tank)
- Summed fuel flow and fuel level sender (single tank)

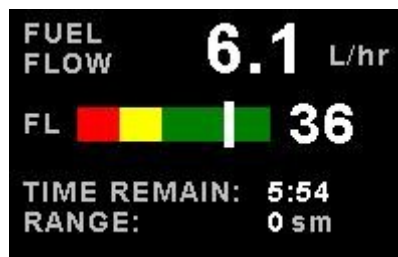

**3.12.5.2 Dual fuel flow and calculated tank levels (dual tank)**

- Dual fuel flow and dual fuel level senders (dual tank)



**3.12.5.3 Single fuel flow and dual fuel level senders (dual tank)**

- Single fuel flow, single fuel level sender, single calculated tank
- Differential fuel flow and dual fuel level senders (dual tank)
- Differential flow, single fuel level sender, single calculated tank
- Summed fuel flow and dual fuel level senders (dual tank)
- Summed fuel flow, single fuel level sender, single calculated tank



**Single/Differential/Summed fuel flow, single fuel level sender, single calculated tank**

These modes are nice for multiple fuel tanks whereby one or more tanks are difficult to insert level senders in. Potential problems such as those listed below can easily be diagnosed by doing side by side comparisons between a calculated and physical tank.

- Leaks in the fuel system
- Uneven drain of interconnected tanks
- Malfunction of the level sender
- Malfunction of the flow sender

**3.12.5.4 Single fuel flow only indicator**

This mode is displayed if either fuel flow 1 or fuel flow 2 is selected and no fuel level senders are selected.

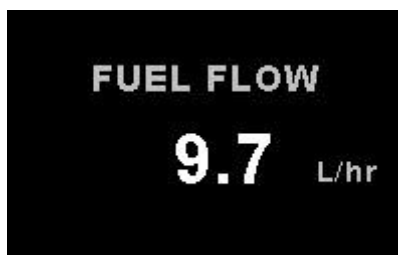

**3.12.5.5 Dual fuel flow indicator**

This mode is displayed if both fuel flow 1 and fuel flow 2 are selected and the fuel mode is selected for dual flow. Both fuel level senders are disabled.



**3.12.5.6 Single tank level indicator**

This mode is displayed if either fuel level 1 or fuel level 2 is selected. Both fuel flow senders are disabled.

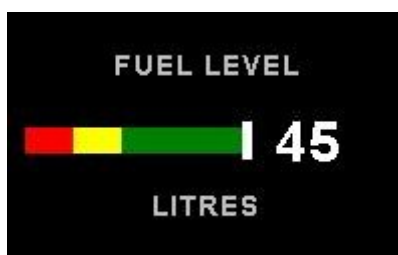

**3.12.5.7 Dual tank level indicator**

This mode is displayed if both fuel level 1 and fuel level 2 are selected. Both fuel flow senders are disabled.



**3.12.5.8 Differential/Summed fuel flow**

This mode is displayed if both fuel flow 1 and fuel flow 2 are selected and the fuel mode is selected for either differential or summed.



**3.12.5.9 Calculated Fuel Tanks**

Calculated fuel tanks will have the text "CALC" in the fuel bar to indicate that the fuel level is calculated from fuel flow and that it is not a physical measure of the fuel tank.



**3.12.5.10 Fuel at Waypoint and GPS Fix Status**

The XTreme-EFIS will display the fuel remaining at the waypoint once an active waypoint has been selected. The GPS fix status is located next to the fuel range. AQ=acquiring (Red text color), 2D=2D fix, 3D=3D fix.



### 3.12.6 EGT/CHT display section

The XTreme-EFIS supports up to 12 thermocouples for EGTs/CHTs. The EGT/CHT section will automatically try and maximize the display area according to the number of EGTs/CHTs selected. The EGT/CHT parameters can be configured in the "EGT SETUP" and "CHT SETUP" menu.

The EGT/CHT number will highlight to the indicated the temperature value if "HIGHEST" is selected. The EGT highlight color is magenta, and the CHT color is cyan.

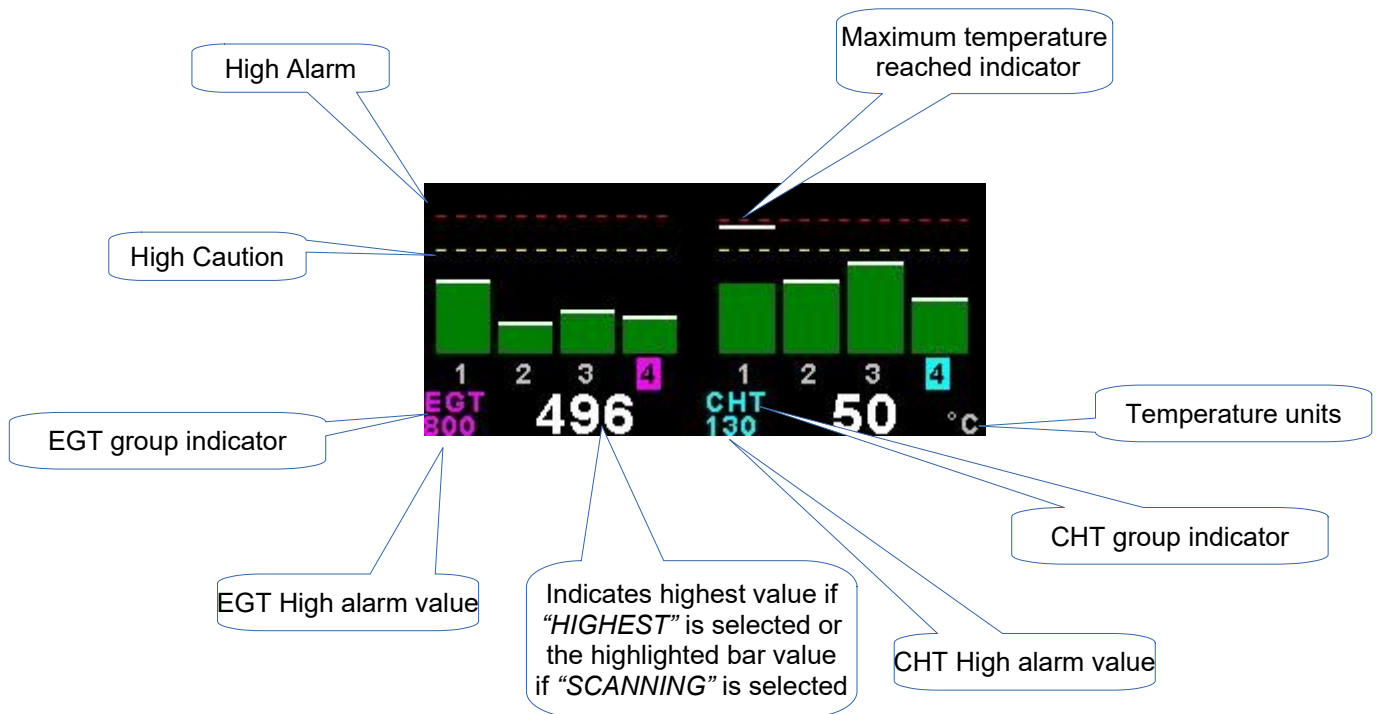

### 3.13 EMS Quick Select Menu System

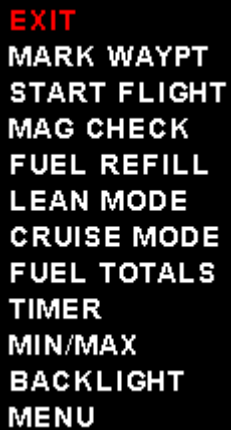

**EXIT**  
**MARK WAYPT**  
**START FLIGHT**  
**MAG CHECK**  
**FUEL REFILL**  
**LEAN MODE**  
**CRUISE MODE**  
**FUEL TOTALS**  
**TIMER**  
**MIN/MAX**  
**BACKLIGHT**  
**MENU**

Press the rotary control when the EMS screen is displayed to access the EMS quick select menu.

***MARK WAYPOINT:***

See section 3.2 for more information.

***START FLIGHT:***

See section 3.2 for more information.

***MAG CHECK:***

See section 3.12.3 for more information.

***FUEL REFILL:***

See section 3.5 for more information.



**LEAN MODE:**

EGT information is also very useful for fuel mixture control. As the fuel mixture is leaned, so the exhaust gasses get hotter. This rise in temperature is a sign of increased combustion efficiency as the optimum mixture setting is approached. If the leaning progresses past a certain point however, the temperature will begin to drop. This temperature drop is the result of reduced energy output from the diminished fuel flow. The best operating mixture for aircraft engines is in the vicinity of this peak EGT reading. The XTreme-EFIS has a special Leaning mode, which easily identifies the peak EGT condition allowing you to adjust your fuel mixture for best performance. Fuel mixture should be adjusted once you have decided on a suitable cruise power setting (typically 70%). Once leaning mode has been enabled, the "LEAN MODE" label is displayed at the bottom left of the EMS display to clearly differentiate it from the normal operating mode. As the fuel mixture is slowly leaned past the point at which the temperature begins to drop (by more than 10°C/15°F), the absolute EGT temperatures will change to show the EGT reading relative to this peak. The sequential order as each cylinder peaks is also shown as numeric text under the cylinder. Leaning mode can be canceled by pressing the soft key to "OFF" or by changing the display screen.

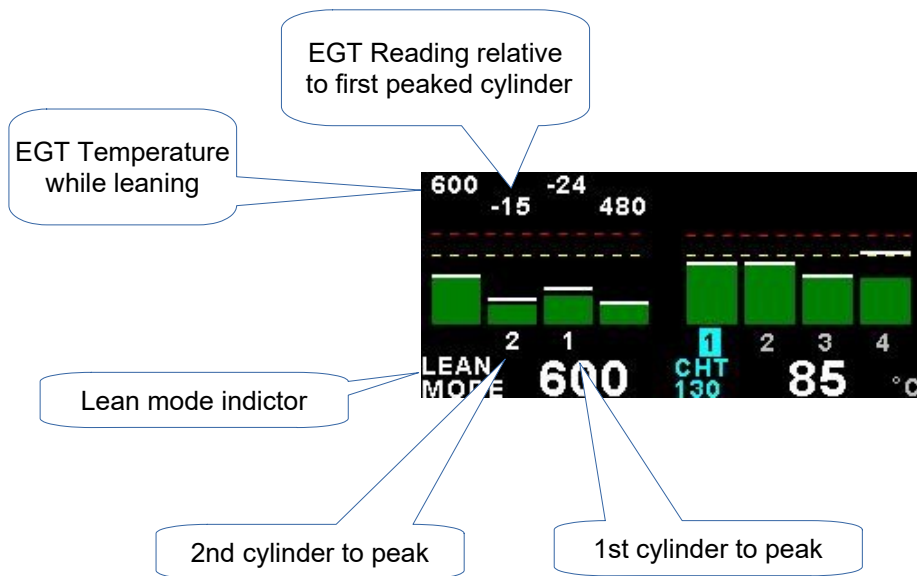

**CRUISE MODE:**

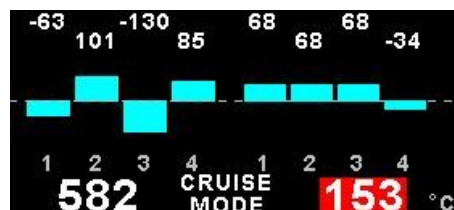

Once cruise mode has been enabled, the "CRUISE MODE" label is displayed at the bottom of the EMS display to clearly differentiate it from the normal operating mode. All EGT and CHT readings are immediately sampled as reference temperatures for the cruise. The display then shows EGT and CHT values relative to this reference temperature. Cruise mode can be canceled by pressing

**FUEL TOTALS:**

See section 3.5 for more information.

**TIMER:**

See section 3.2 for more information.

**MIN/MAX:**

See section 3.2 for more information.

**BACKLIGHT:**

See section 3.2 for more information.

**MENU:**

Select this menu option to enter the main menu system.

### 3.14 GPS Display

The GPS page shows the GPS information in an easy to read format. Sunrise/sunset times as well as the magnetic variation is shown.

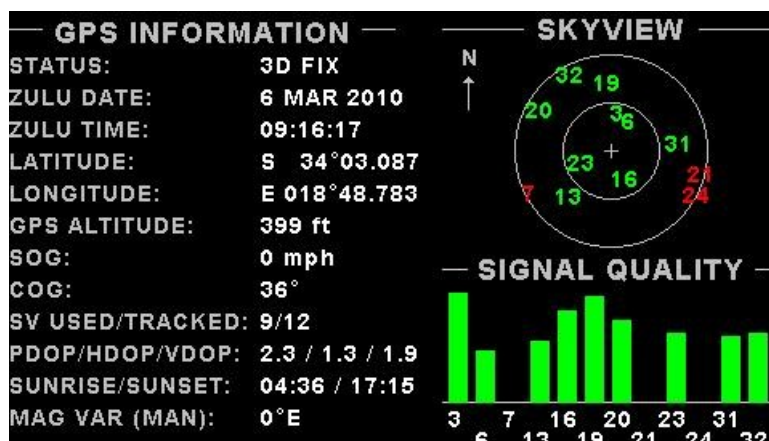

### 3.15 GPS Quick Select Menu System



Press the rotary control when the GPS screen is shown to access the GPS quick select menu.

**BACKLIGHT:**

See section 3.2 for more information.

**MENU:**

Select this menu option to enter the main menu system.

### 3.16 Information / Checklist Display

The Information / Checklist page shows checklists and graphic information pages which are loadable from the SD card.

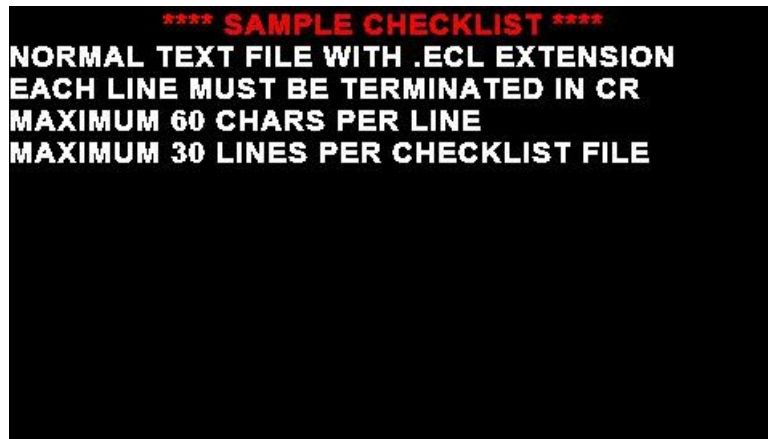

#### 3.16.1 Graphic information pages

The graphic information page allows you to display any type of image on the XTreme-EFIS high resolution graphics display.

##### Creating your own graphic information pages

**You will need:**

- A bitmap picture of your choice (\*.BMP, 480x272 pixel resolution)
- The BMP to MIF converter tool can be downloaded free of charge from <http://www.mglavionics.co.za> or can be found on the XTreme-EFIS distribution SD card).

The BMP to MIF program is used to convert images in Windows BMP format to MIF format. You can use this program to make your own startup screen (Splash screen) and graphic information pages. The color depth is limited to 256 colors.

Run the XTreme Image Maker program.

Load an image file (and remember the location), select the resolution as width (480) and height (272) and press the GO button. The new MIF image will be located in the same directory as the source (.BMP) file. Copy the created file (.MIF extension) to the Infopage directory on the SD card.

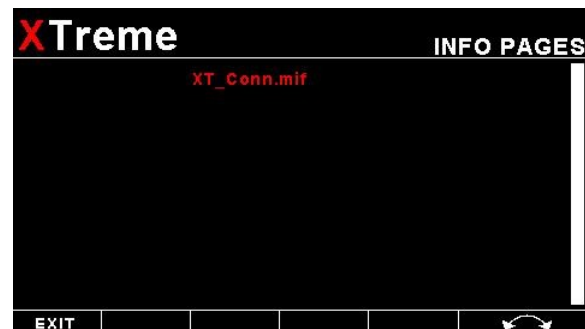
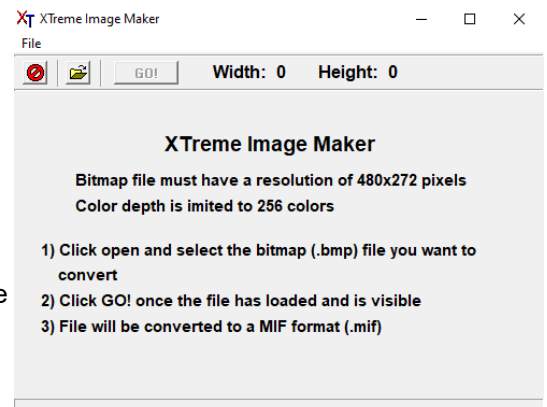

The graphic information file can then be loaded by pressing the rotary control and selecting "INFO PAGES". A window containing all the files with the .MIF extension is shown. Select the desired information page. The number of information pages that can be stored and displayed depends on the size of the SD card.

### 3.16.2 Checklists

A checklist file is simply a text file created in a word processing program and saved with a .ECL extension. The name of the file does not matter but we suggest calling it something familiar so you can easily identify it. The length of each text line must not be more than 60 characters and must be terminated with an Enter (CR). The line will automatically be truncated at the end of the right hand side of the screen. Each checklist file must not be more than 30 lines.

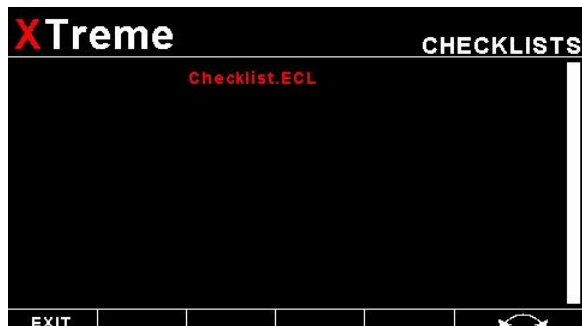

Copy the created file (.ECL extension) to the checklst directory on the SD card when you are complete. The checklist file can be loaded by pressing the rotary control and selecting “CHECKLISTS”. A window containing all the files with the .ECL extension will be shown. Select the checklist you require. The number of checklists that can be stored and displayed depends on the size of the SD card.

### 3.17 Information/Checklist Quick Select Menu System

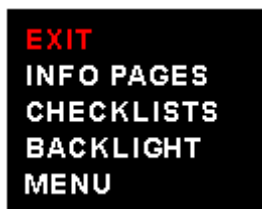

Press the rotary control when the Info / Checklist screen is shown to access the Info / checklist quick select menu.

#### **INFO PAGES:**

This menu option selects a graphic information page to display. A window will open displaying all the files with the .MIF extension in the Infopage directory on the SD card. Press the rotary control over the file you wish to load as a graphic information page.

#### **CHECKLISTS:**

This menu option selects a checklist to display. A window will open displaying all the files with the .XCL extension in the Checklst directory on the SD card. Press the rotary control over the file you wish to load as a checklist.

#### **BACKLIGHT:**

See section 3.2 for more information.

#### **MENU:**

Select this menu option to enter the main menu system.

### 3.18 Waypoints

The XTreme-EFIS has 2 databases that it uses for waypoints. A “NAVIDATA” and a user “SUPPLEMENTARY” database.

The Navidata database is compiled by the MGL Central application. There are precompiled navidata databases for most countries on the XTreme-EFIS distribution SD Card and also from various MGL websites. Alternatively Waypoint and airport data can be obtained for many areas of the world through the free service provided at [www.navaid.com](http://www.navaid.com) web site. Download data for your region in GPX format. This can be imported into the MGL Central application. Please note that the navidata database must be in a version 5 format and must not be encrypted. If you are unsure of the version then import the navidata file into the latest version of the MGL central application and then re-export it again. THE NAVIDATA.EWD FILE MUST RESIDE IN THE ROOT DIRECTORY OF THE SD CARD.

The user “Supplementary” database is the database that can be created and edited on the XTreme-EFIS using the waypoint menu or in the MGL central application. The file must be called waypoint.ewd and it must RESIDE IN THE ROOT DIRECTORY OF THE SD CARD. Waypoints that are created using the mark function in the quick select menu are saved in this database.

Press the 2<sup>nd</sup> most left softkey during the normal display screens to access the waypoint selection screen. The following screen will be displayed:

**N:** Waypoint is in the navidata database.  
**W:** Waypoint is in the supplemental database.

Distance to waypoint from the current location

XTreme		WAYPOINTS
		GOTO/NEAREST
N	STRFTN Strandfontein	68sm
N	ZA0092 Holrivier Airport,SF	73sm
N	HOLGAT Holgat	73sm
N	VREDDL Vredendal Old Airfield	80sm
N	FAVR Vredendal	83sm
N	ZA-KIG Koingnaas Airport,SF	85sm
N	KOING Koingnaas	85sm
N	VANRYN Van Rhynsdorp	95sm
N	CLANWM Clanwilliam	113sm
N	FACW Clanwilliam Airport,SF	114sm
N	FASD Saldanha	116sm

6 Character short Waypoint name.

Long Waypoint name.

Page up and Page down softkeys.

Scroll up and down through the waypoint list

The nearest 100 waypoints to your current location is displayed.

**Searching Waypoints:**

Press the search waypoint to search the navigation databases if the required waypoint is not in the list. The following screen is displayed:



Use the rotary control to enter the search string for the short name. Once the required waypoint is visible in the list press the "LIST" softkey. Use the rotary control to scroll up and down the list. Press the rotary control to select the required waypoint.

### 3.19 Routes

The XTreme-EFIS has the ability to fly preset routes. Press the middle softkey during the normal display screens to access the route selection screen. The following screen will be displayed:

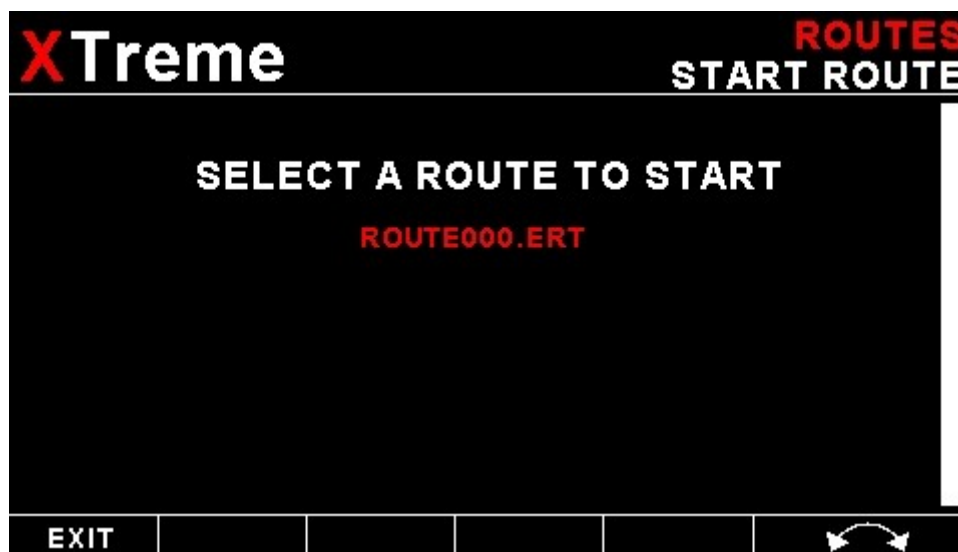

Once a route has been selected then select the route flying direction

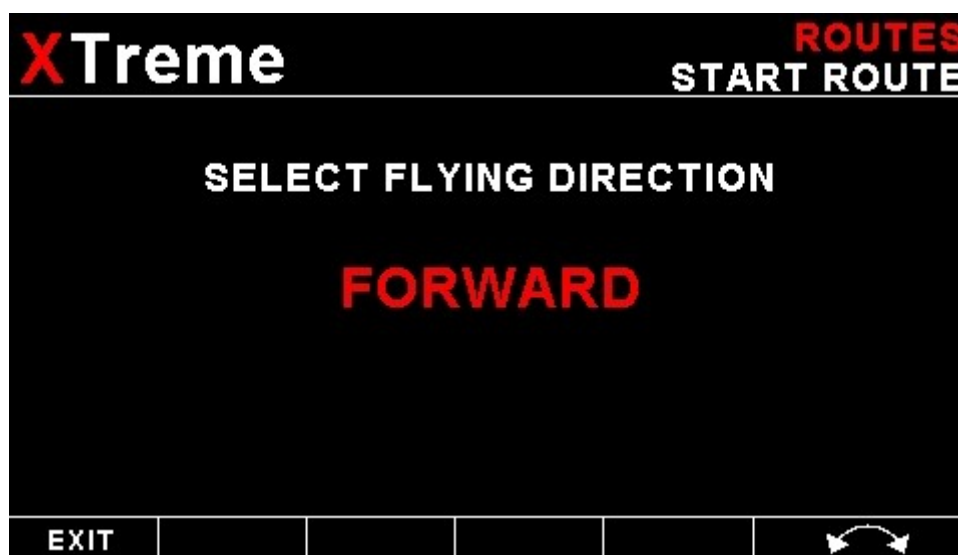

The first or last waypoint will be selected depending on which direction was selected.

If the middle softkey is pressed again when a route is active then the following screen will be displayed.



A new waypoint in the route can be selected, the flying direction can be changed or the route can be canceled.



# 4 Main Menu System

- EXIT
- MARK WAYPT
- START FLIGHT
- REALIGN AHRS
- LEVEL PITCH
- ALTITUDE BUG
- HEADING BUG
- TIMER
- MIN/MAX
- BACKLIGHT
- MENU**

To access the main menu system, press the rotary control knob, scroll down to the "MENU" option and press the rotary control knob again. Use the rotary control to navigate through the menu system.

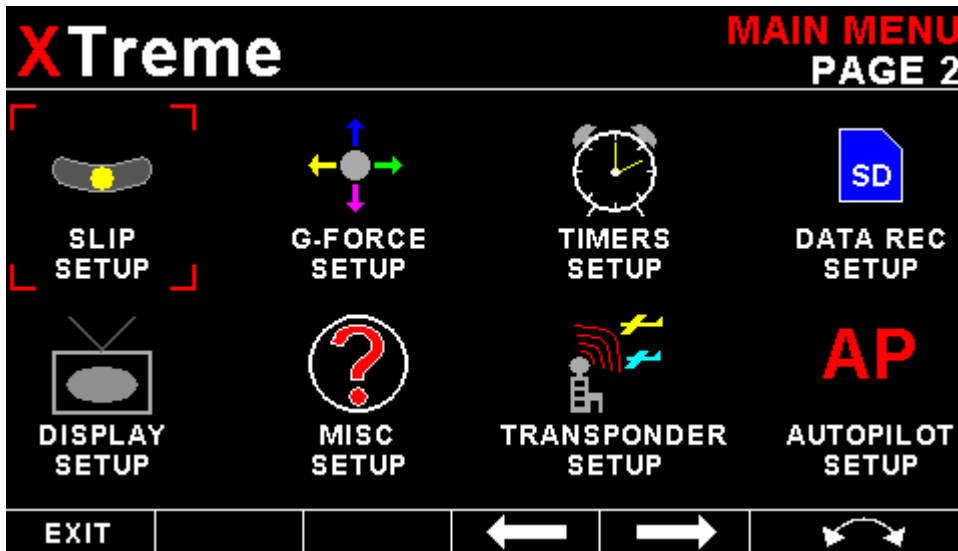
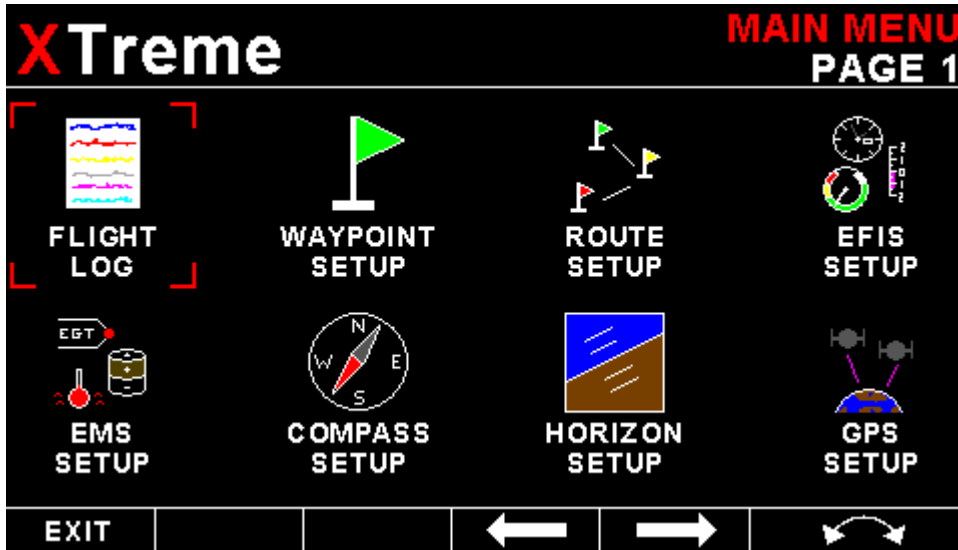

### 4.1 Menu Sub-Bar



Use the menu sub-bar for quick menu navigation. Select the soft key directly under the text to activate that function. Note that when entering certain menu options, the multiplier text will appear to make it easier to enter large numbers.



## 4.2 Flight Log

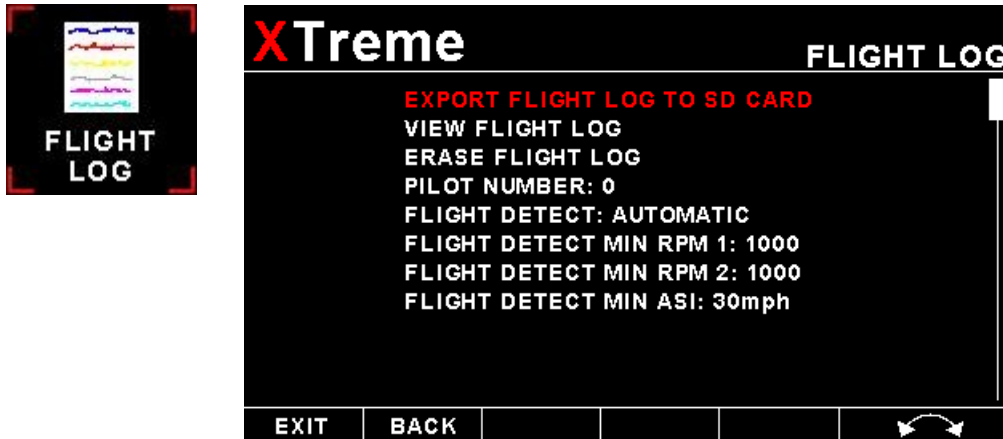

**NOTE:** The Flight log is stored in RAM and is updated every minute. If the power is turned off to the XTreme-EFIS before the flight has ended then the flight information after the last minute update will be lost.

### **EXPORT FLIGHT LOG TO SD CARD (.CSV):**

Use this function to export the current flight logs stored in the XTreme-EFIS to a SD card. The exported filename is called XTFLIGHT.CSV. The exported flight log is exported in a CSV (Comma Separated Values) file format and can be imported into a spread sheet type program.

### **VIEW FLIGHT LOG:**

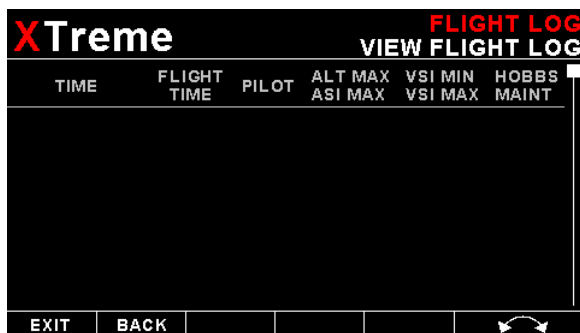

This allows the pilot to view the last 100 recorded flights.

### **ERASE FLIGHT LOG:**

Use this function to erase the current flight log stored in the XTreme-EFIS.

### **PILOT NUMBER:**

Select a pilot number under which the next flights will be logged. Every flight entry in the flight log has a pilot number associated to it.

### **FLIGHT DETECT:**

Select if you want the flight log to automatically “AUTOMATIC” start or if you want to manually “MANUAL” start and stop it.

The XTreme-EFIS uses the following algorithm to determine if a flight is in progress (*"AUTOMATIC" mode*): If the airspeed is greater than the preset *"FLIGHT DETECT MIN ASI"* value or the RPM 1 & 2 is greater than the preset *"FLIGHT DETECT MINIMUM RPM1 2"* value for a duration of 60 seconds or more, a flight is started with a logbook entry. The flight ends if ground speed or RPM falls below the preset value for 30 seconds.

The above algorithm ensures that touch-and-goes will not result in the end of a flight and a logbook entry.

***FLIGHT DETECT MINIMUM RPM: (Automatic mode only)***

Enter the minimum RPM 1 threshold that will start a new flight log entry.

***FLIGHT DETECT MINIMUM RPM: (Automatic mode only)***

Enter the minimum RPM 2 threshold that will start a new flight log entry.

***FLIGHT DETECT MINIMUM ASI: (Automatic mode only)***

Enter the minimum airspeed threshold that will start a new flight log entry.

#### **4.2.1 Flight Log output file format .CSV (Comma Separated Values)**

The Xtreme-EFIS will create a Comma Separated Values (.csv) file called XTflight.csv in the root directory of the SD card.

Below is the format of the .CSV data

**Date, Time, Flight Time, Pilot Number, Maximum Altitude, Maximum Airspeed, Minimum VSI, Maximum VSI, Hobbs Timer, Maintenance Timer**

### 4.3 Waypoint Setup

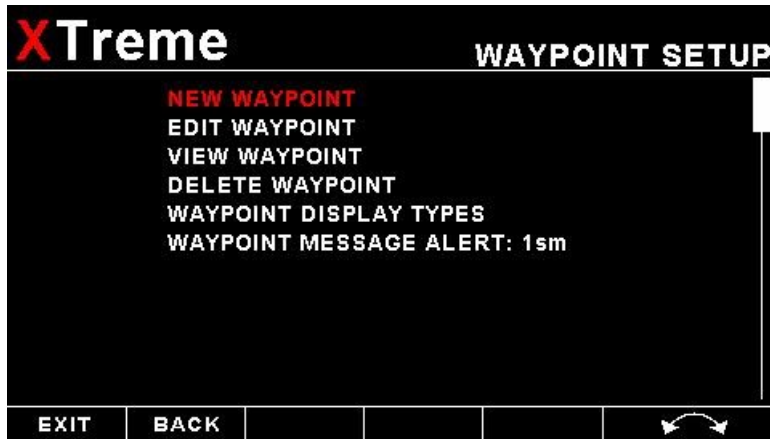

The waypoint setup allows the pilot to edit the supplementary waypoint database.

**NEW WAYPOINT:**

Select this menu option to create a new waypoint.

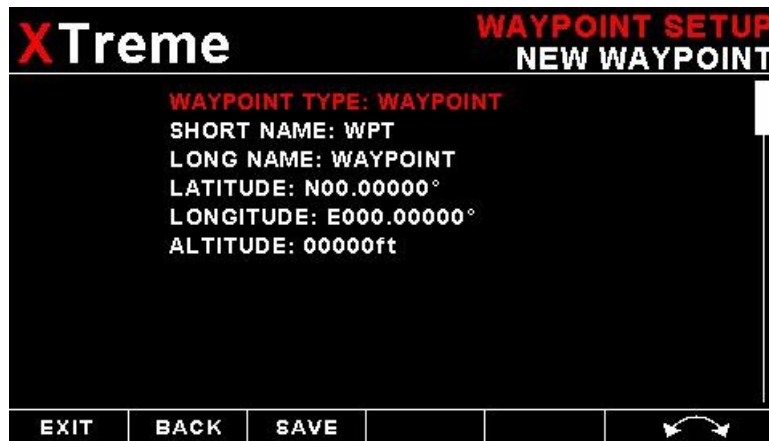

**EDIT WAYPOINT:**

Select this menu option to edit a waypoint.

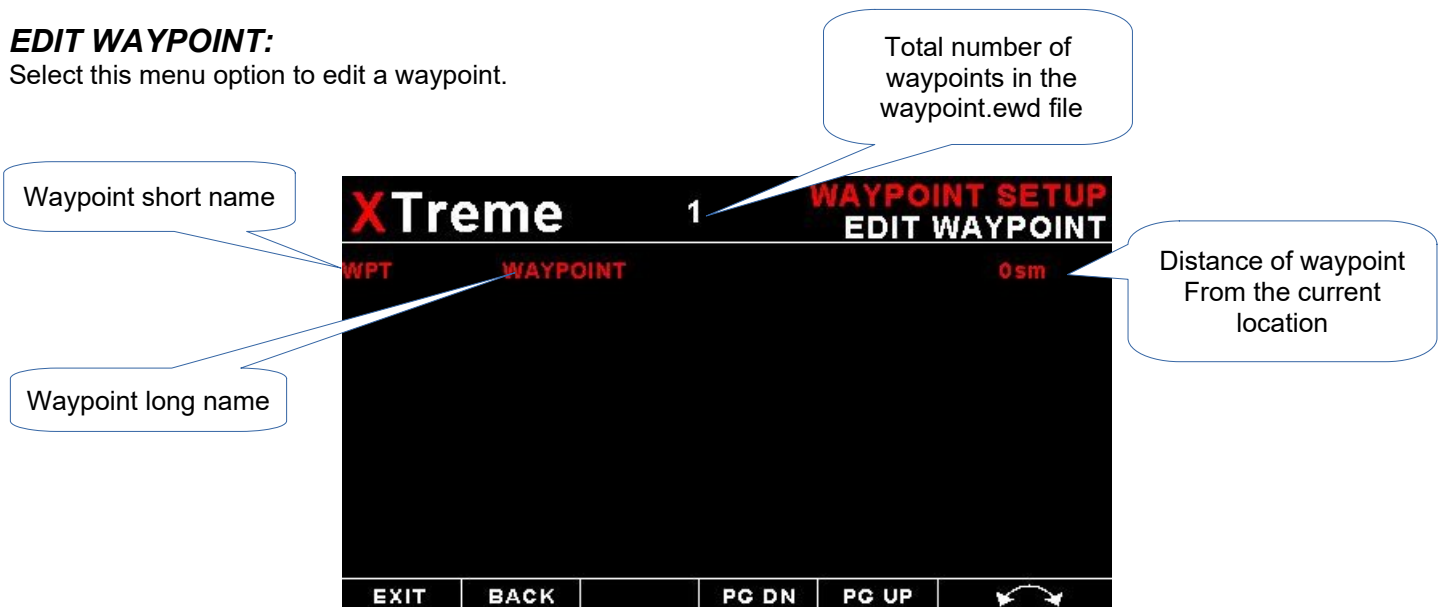

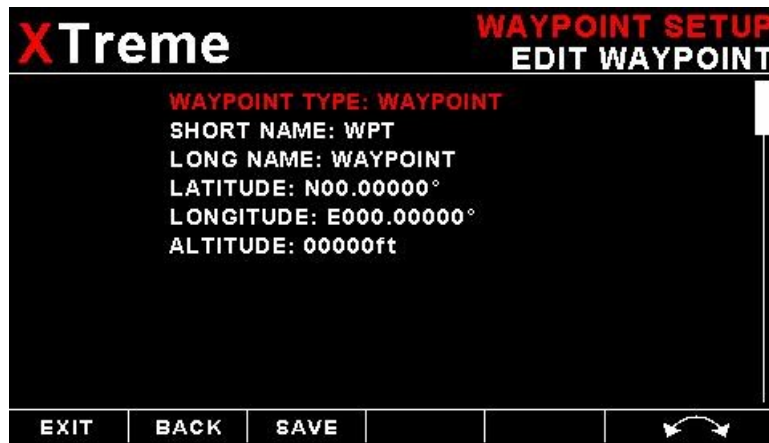

**VIEW WAYPOINT:**

Select this menu option to view a waypoint.

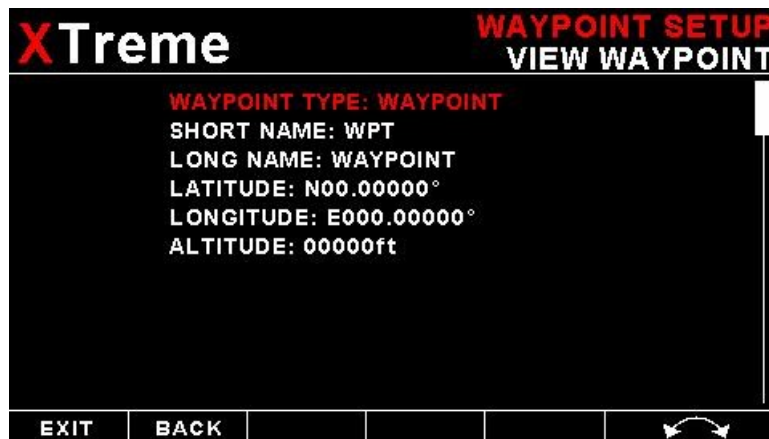
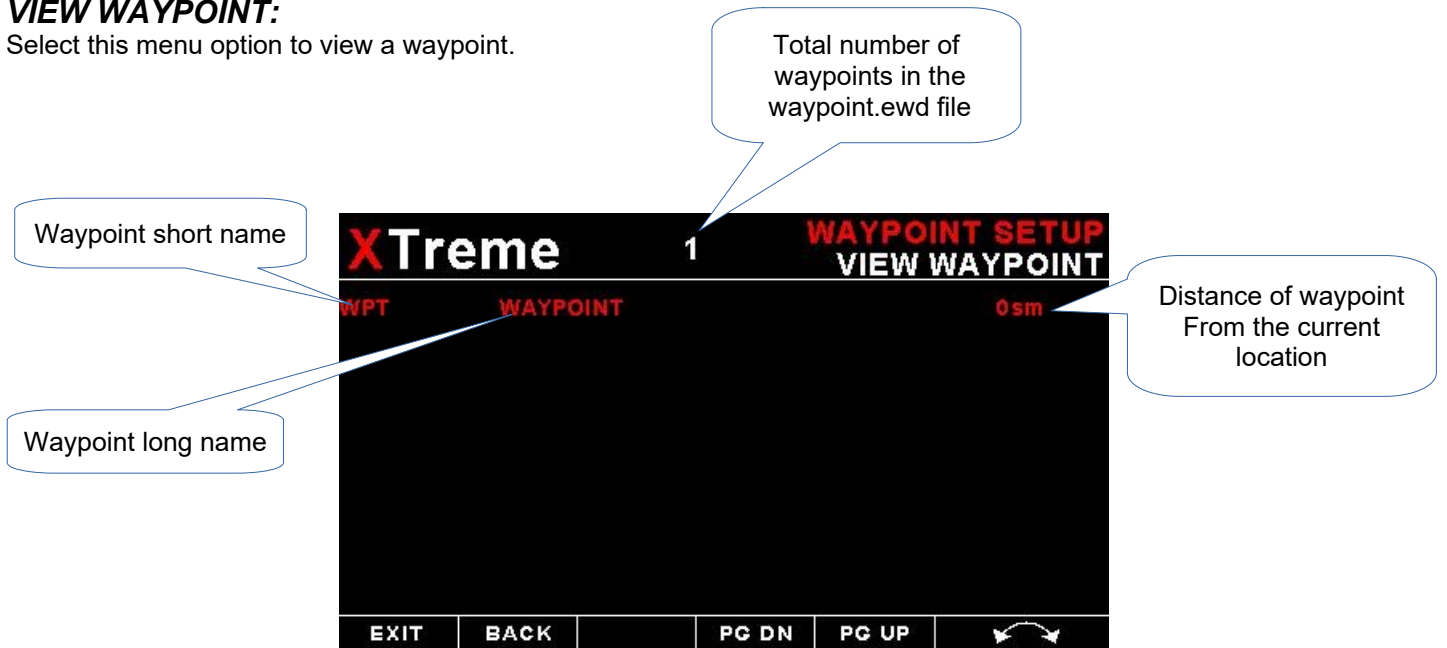

**DELETE WAYPOINT:**

Select this menu option to delete a waypoint.



**WAYPOINT DISPLAY TYPES:**

Select what type of waypoints to display when browsing / searching the navidata file. Selecting only the waypoint types of interest can speed up the database searching considerably.



**WAYPOINT MESSAGE ALERT:**

Enter the distance to the waypoint when the waypoint alert message must be displayed.

### 4.4 Route Setup

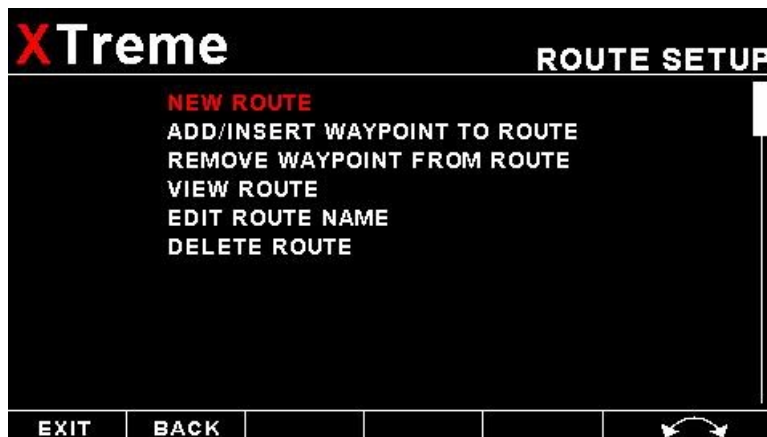

**NEW ROUTE:**

Select this menu option to create a new route. A file with the route name and the extension .ert will be created. It will be created in the root directory of the SD card.

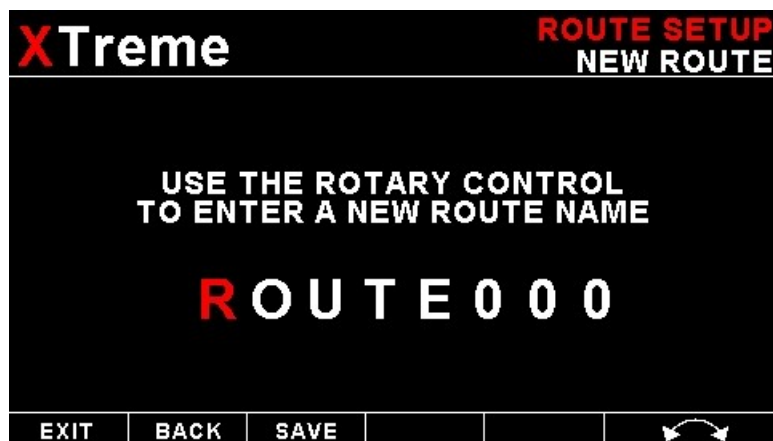

**ADD / INSERT WAYPOINT TO ROUTE:**

Select this menu option to add a waypoint to a route.





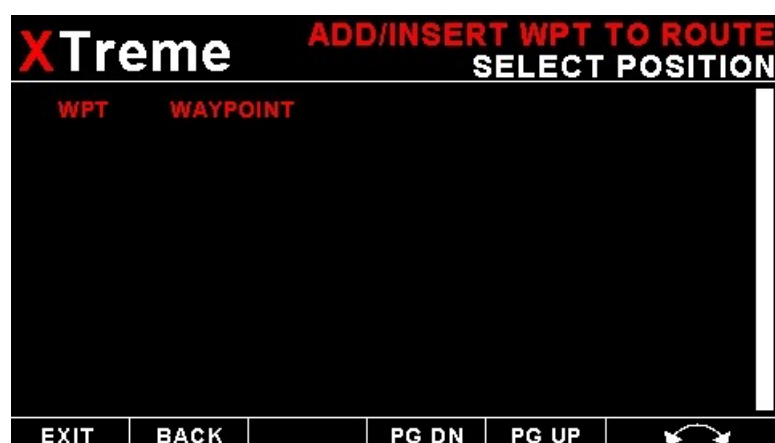
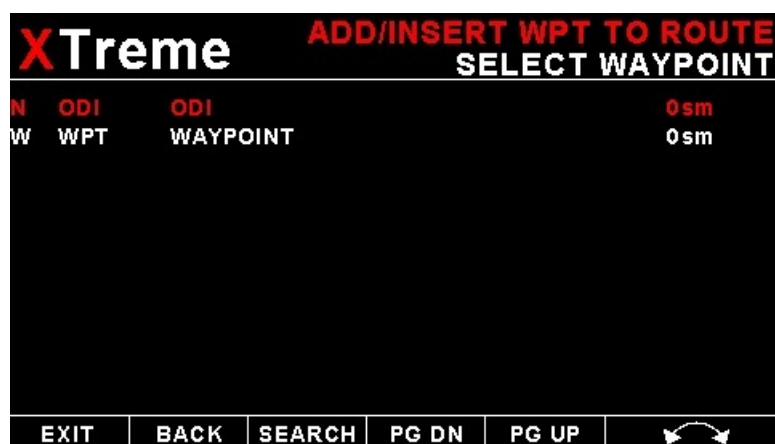

**REMOVE WAYPOINT FROM ROUTE:**  
 Select this menu option to remove a waypoint from a route.



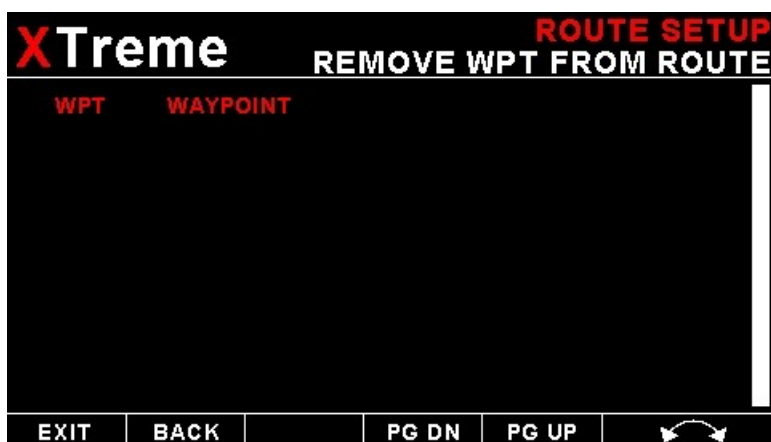

**VIEW ROUTE:**

Select this menu option to view all the waypoints in a route.

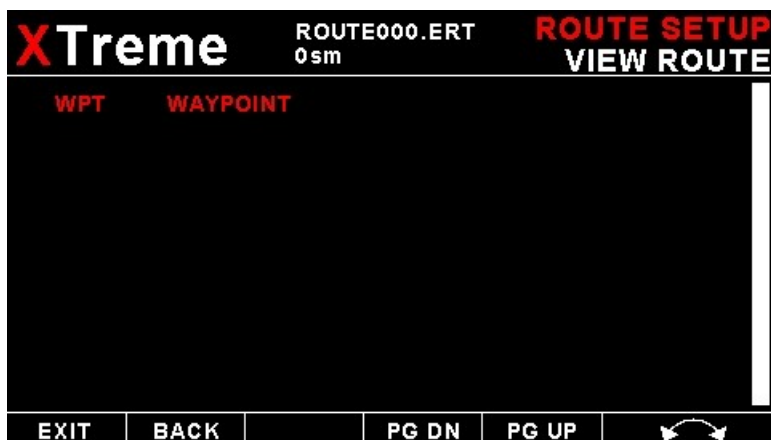
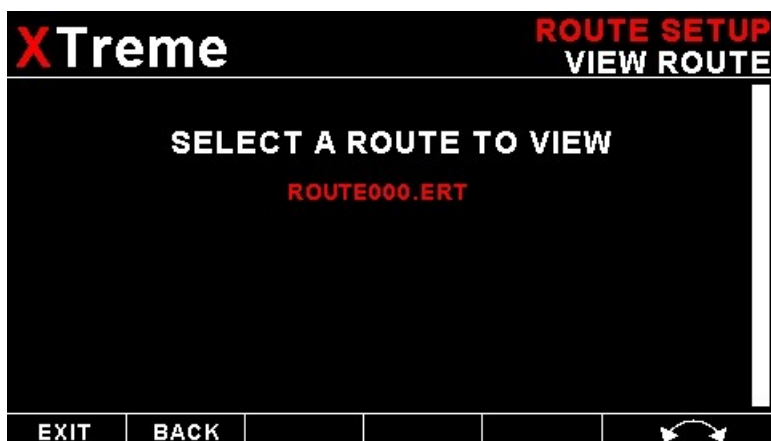

**EDIT ROUTE NAME:**

Select this menu option to edit the route name.

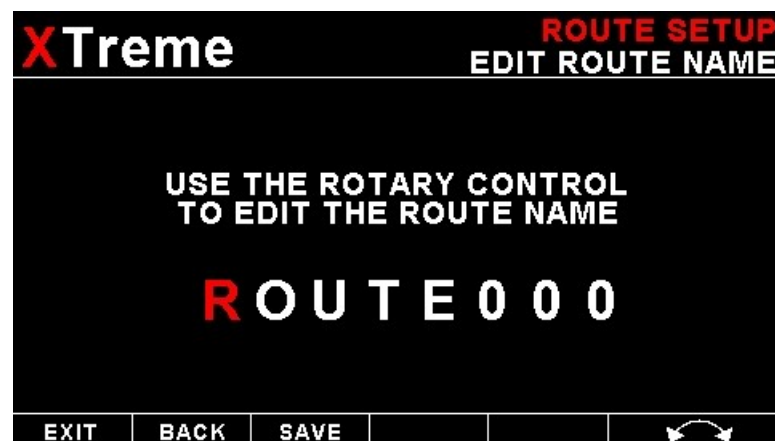

**DELETE ROUTE:**

Select this menu option to delete a route.



### 4.5 EFIS Setup

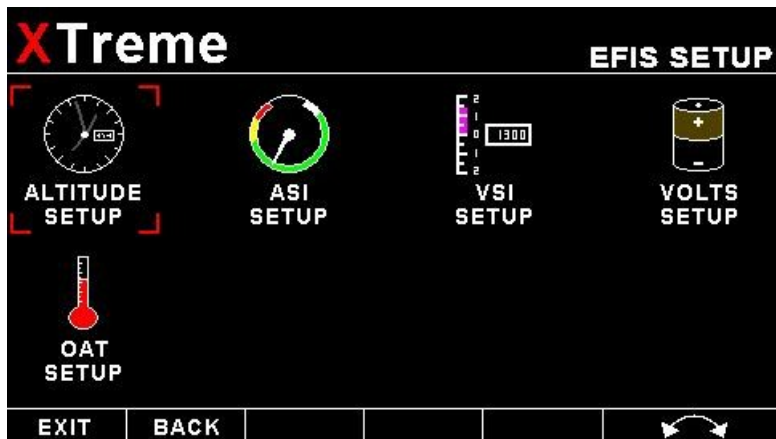

### 4.5.1 Altitude Setup

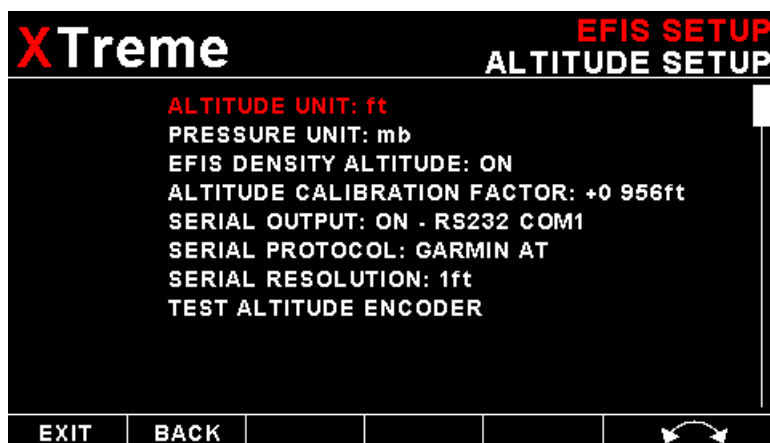

**ALTITUDE UNIT:**

Select if you want the altitude displayed in ft (feet) or m (meters).

**PRESSURE UNIT:**

Select if you want the local pressure displayed in mB (millibars) or “Hg (inches of mercury).

**EFIS DENSITY ALTITUDE:**

This enables or disables the density altitude diisplay on the EFIS and MFD displays.

**ALTITUDE CALIBRATION FACTOR:**

This is the pressure sensor offset in 0.1mB increments. Adjust the calibration factor so the altitude readout agrees with your pitot static test set.

Should you have access to an accurate reference you may use this function to calibrate your altimeter. Before you do this, ensure that your calibrated and certified reference is set to the local pressure of 1013.25mB (29.92”HG). Your altimeter has been calibrated by the factory to an accuracy of +/- one mB or approximately +/- 30 ft (10m) at sea level.

**SERIAL OUTPUT:**

Select “ON” to enable the RS232 serial altitude output on COM1 or on COM2. This formatted serial RS232 message can be directly interfaced to various RS232 serial input transponders. If a parallel Gillham output is required then a CNV-ALT can be purchased from your MGL Avionics distributor to convert the RS232 output to a parallel Gillham output.

**SERIAL PROTOCOL:**

Select the protocol of the serial RS232 output message. The protocol can be selected between GARMIN AT, Magellan, Northstar/Garmin, Trimble/Garmin, MGL Avionics and Microair UAV. Please note that the baud rate is automatically adjusted according to which protocol is selected. The output format is as follows. The message contains the current pressure altitude with a fixed reference to 1013.25mB (29.92 inches mercury). All protocols use 8 databits, no parity, and 1 stop bit. The message is outputted once a second.

Protocol	Baud Rate	Message format	Example
Garmin AT	1200	#AL, space, +/-, five altitude digits right justified zero padded, T+25, checksum, carriage return  The checksum is a simple modulo 256 sum of the binary values of the individual characters. The checksum is sent as two	#AL +02372T+25DF[CR]

		characters in hexadecimal format	
Magellan	1200	#MGL, +/-, five altitude digits right justified zero padded, T+25, checksum, carriage return  The checksum is a simple modulo 256 sum of the binary values of the individual characters. The checksum is sent as two characters in hexadecimal format	\$MGL+02372T+2513[CR]
Northstar, Garmin	4800	ALT, space, five altitude digits right justified zero padded, carriage return	ALT 02372[CR]
Trimble, Garmin	9600	ALT, space, five altitude digits right justified zero padded, carriage return	ALT 02372[CR]
MGL Avionics	9600	ALT, +/-, five altitude digits right justified zero padded ,1013.25mB (29.92”Hg) referenced, C, +/-, five altitude digits right justified zero padded (corrected to local pressure), L, local pressure setting in millibars,+/-, four digit VSI reading right justified zero padded in ft/min, X, checksum, carriage return  The checksum is a simple modulo 256 sum of the binary values of the individual characters. The checksum is sent as two characters in hexadecimal format	ALT+02372C+02372L1013+0000XCA[CR]
Microair UAV	9600	STX,a,=, five altitude digits right justified zero padded, ETX	[STX]a=02372[ETX]
STX=0x02 ETX=0x03 CR=0x0D			

**SERIAL RESOLUTION:**

Select the resolution of the output altitude data, a selection of 1,10,25 or 100 ft can be selected.

**TEST ALTITUDE ENCODER:**

This is a handy function to test the EFIS transponder interface once the installation has been completed. The serial output will output specific altitudes which can then can be used to test the serial RS232 output and the parallel gillham output if using a CNV-ALT converter. The XTreme-EFIS will resume the normal output of the indicated altitude upon exiting the test function.

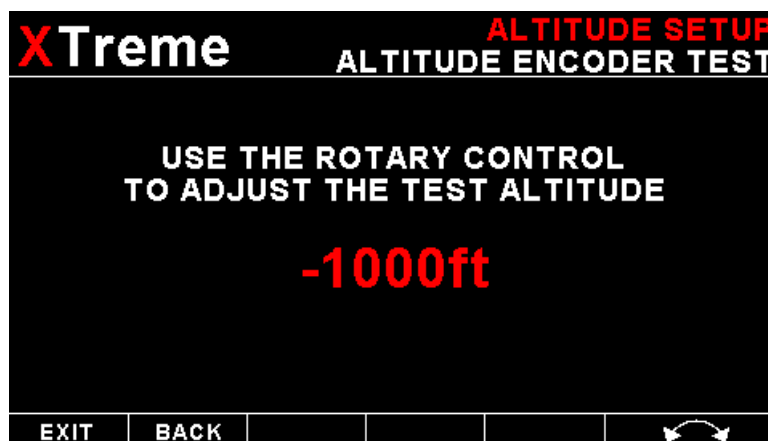

The following codes are outputted:

<b>Altitude</b>	<b>D4</b>	<b>A1</b>	<b>A2</b>	<b>A4</b>	<b>B1</b>	<b>B2</b>	<b>B4</b>	<b>C1</b>	<b>C2</b>	<b>C4</b>
-1000ft	0	0	0	0	0	0	0	0	1	0
-900ft	0	0	0	0	0	0	0	1	1	0
-700ft	0	0	0	0	0	0	1	1	0	0
-400ft	0	0	0	0	0	0	1	0	1	1
-200ft	0	0	0	0	0	1	1	0	0	1
800ft	0	0	0	0	1	1	0	0	0	1
2800ft	0	0	0	1	1	0	0	0	0	1
6800ft	0	0	1	1	0	0	0	0	0	1
14800ft	0	1	1	0	0	0	0	0	0	1
30800ft	1	1	0	0	0	0	0	0	0	1

Each altitude reporting code line must be tested for integrity of connection if at any time the aircraft connections to the transponder or altitude data source have been removed and reconnected. Integrity of the connections may be verified by performing a test of mode C function of the transponder system.

**Warning:** Do not use this function while in flight as incorrect altitude information will be sent to the transponder.

### 4.5.2 Airspeed Setup



**XTreme**
**EFIS SETUP  
ASI SETUP**

---

**ZERO ASI SENSOR**

ASI UNIT: mph  
 ASI FILTER: FAST  
 ASI SPAN (TAPE&DIAL): 350mph  
 ASI IN VIEW (TAPE): 20%  
 Vne (NEVER EXCEED SPEED): 220mph  
 Vno (MAX MANEUVERING SPEED): 180mph  
 Vfe (MAX FLAP SPEED): 50mph  
 Vs1 (MIN SAFE SPEED, NORMAL): 30mph  
 Vs0 (MIN SAFE SPEED, LANDING): 20mph  
 Vx (BEST ANGLE OF CLIMB): 80mph

EXIT
BACK



↔

---

Vy (BEST RATE OF CLIMB): 100mph  
 Vs ALARM: ON  
 Vne ALARM: ON  
ASI CALIBRATION FACTOR: 100% 0mph

**ZERO ASI SENSOR:**

This setup allows your instrument to measure the zero airspeed reading of the airspeed sensor and set a calibration value internally for this. This is equivalent to some mechanical airspeed indicators that have an adjustment to set the needle to zero when the aircraft is not moving. You would use this function occasionally if you see an airspeed reading when the aircraft is at rest. This may be caused by aging of the built in pressure sensor or related electronics. When this function is performed make sure that there is no air flow into the pitot tube as this would result in an incorrect internal calibration.

**XTreme**
**ASI SETUP  
ZERO ASI**

**ARE YOU SURE YOU WANT TO  
ZERO THE ASI SENSOR**

NO                      YES

ASI PRESSURE: 0.00mB

**ASI UNIT:**

Select if you want the ASI to be displayed in mph (statute miles per hour), km/h (kilometers per hour) or kts (nautical miles per hour).

**ASI FILTER:**

This function can be used to select the signal filter time constant. Selections are "NONE", "FAST" or "SLOW". This selection influences the rate at which your ASI can change its reading. If you have an installation that suffers from strong turbulence at the pitot tube, select "slow". If you have a very clean airflow in front of the pilot tube you can select "fast" which will give you a faster response to airspeed changes.



**ASI SPAN (TAPE&DIAL):**

Select the maximum value that you want the airspeed tape & dial displays to show. This can give you increased display resolution.

**ASI IN VIEW (TAPE):**

Adjust this setting to set the amount of tape to view. For example, setting this value to 30% and your "ASI SPAN" to 250 will result in the tape showing 75 on the display at a time.

**Vne (MAX EXCEED SPEED):**

Enter you maximum speed you aircraft should not exceed.

**Vno(MAX MANEUVERING SPEED):**

Enter your maximum maneuvering speed.

**Vfe (MAX FLAP SPEED):**

Enter the maximum speed that is permissible with the flaps extended.

**Vs1 (MIN SAFE SPEED, NORMAL):**

Enter your minimum safe speed for normal flight of your aircraft

**Vso (MIN SAFE SPEED, LANDING):**

Enter your minimum safe speed for landing your aircraft

**Vx (BEST ANGLE OF CLIMB):**

Enter your best angle of climb for your aircraft

**Vy (BEST RATE OF CLIMB):**

Enter your best rate of climb for your aircraft

**Vs ALARM:**

This enables or disables Vs Alarm

**Vne ALARM:**

This enables or disables the VNE alarm.

**ASI CALIBRATION FACTOR:**

During the factory calibration a factor has been determined and entered here that will give you accurate airspeed, provided your pitot tube is not influenced by pressure effects caused by airflow around your airframe. The calibration is displayed in % of the reading, you can increase or decrease the reading if required to help cancel out under or over reading of the airspeed indicator on your aircraft.

### 4.5.3 VSI Setup

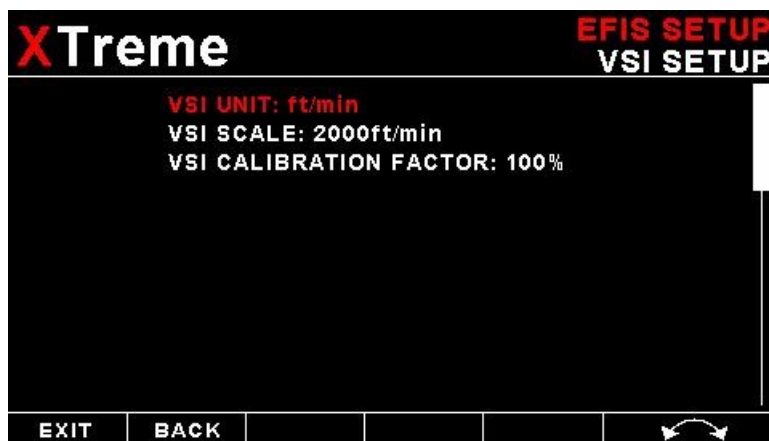

#### **VSI UNIT:**

Select if you want the VSI to be displayed in "*ft/min*" (feet/minute) or "*m/s*" (meters/second).

#### **VSI SCALE:**

Select the VSI scale most suited for your aircraft.

#### **VSI CALIBRATION FACTOR:**

This is a function that is used to calibrate your VSI to read exact rates of climb or decent. This function works as a percentage of initial reading. The default setting for this function is 100%. Increasing this value increases the VSI reading and decreasing the value decreases the reading.

#### **Suggested VSI calibration method**

After you have installed the instrument, perform a calibration flight. This should be done in very calm conditions. Turbulence and thermal activity will make accurate calibration impossible. Many areas have ideal conditions during early mornings or late afternoons. Place the instrument in ft/min for ease of calibration. Take your aircraft to a few thousand feet above ground and start a glide with a low power setting. Take a stopwatch and when the glide is stable (stable VSI reading) start the stopwatch. Take note of your altimeter reading at the same time. Continue the stable glide for one minute exactly. After the minute has finished, take another reading of your altimeter.

#### **Example:**

VSI reading during stable glide: -400 ft/min

Start altitude: 2500 ft.

End altitude: 2050 ft.

In the above example the VSI is under reading by about 12%. Set your VSI calibration to 112% to cancel out the error.

### 4.5.4 Volts Setup

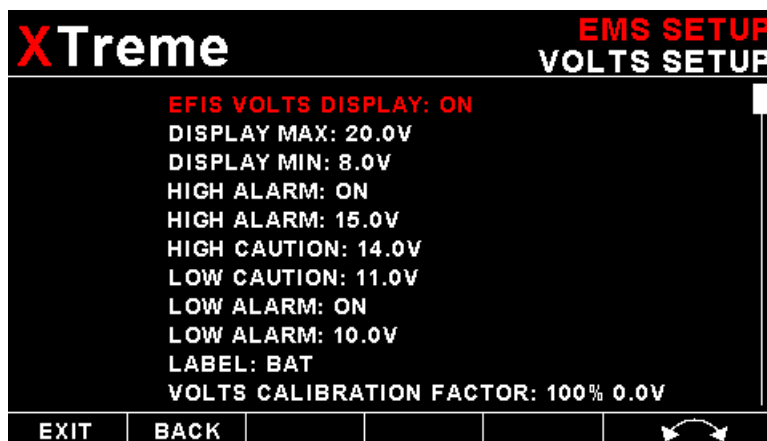

**EFIS VOLTS DISPLAY:**

This enables or disables the volts display on the EFIS and MFD displays.

**DISPLAY MAX:**

Select the maximum value that you want the volts bargraph in the EMS display to show. This can give you increased display resolution.

**DISPLAY MIN:**

Select the minimum value that you want the volts bargraph in the EMS display to show. This can give you increased display resolution.

**HIGH ALARM:**

This enables or disables the volts high alarm.

**HIGH ALARM:**

Enter the voltage threshold for when the high alarm must be activated. Any voltage above this value will activate the alarm.

**HIGH CAUTION:**

Enter the voltage for the high caution. This is the lower value of the upper yellow band.

**LOW CAUTION:**

Enter the voltage for the low caution. This is the upper value of the lower yellow band.

**LOW ALARM:**

This enables or disables the volts low alarm.

**LOW ALARM:**

Enter the voltage threshold for when the low alarm must be activated. Any voltage below this value will activate the alarm.

**LABEL:**

Enter a label to easily identify your Volts reading.

**VOLTS CALIBRATION FACTOR:**

During the factory calibration a factor has been determined and entered here that will give you an accurate volts reading. If you would like to adjust this value then measure the supply voltage with a multimeter and adjust the calibration factor until the XTreme-EFIS matches that of the multimeter.

## 4.5.5 OAT Setup

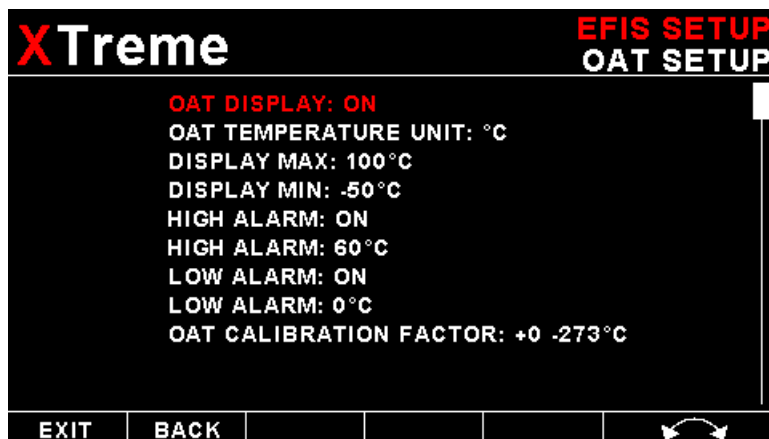

### **OAT DISPLAY:**

This enables or disables the OAT display on the EFIS, MFD and EMS displays.

### **OAT TEMPERATURE UNIT:**

Select whether you want the OAT to be displayed in degrees Celsius (°C) or in degrees Fahrenheit (°F).

### **DISPLAY MAX:**

Select the maximum temperature that you want the OAT bargraph in the EMS display to show. This can give you increased display resolution.

### **DISPLAY MIN:**

Select the minimum temperature that you want the OAT bargraph in the EMS display to show. This can give you increased display resolution.

### **HIGH ALARM:**

This enables or disables the OAT high alarm.

### **HIGH ALARM:**

Enter the temperature threshold for when the high alarm must be activated. Any temperature above this value will activate the alarm.

### **LOW ALARM:**

This enables or disables the OAT low alarm.

### **LOW ALARM:**

Enter the temperature threshold for when the low alarm must be activated. Any temperature below this value will activate the alarm.

### **OAT CALIBRATION FACTOR:**

During the factory calibration a factor has been determined and entered here that will give you an accurate OAT reading. If you find this value is incorrect then adjust the calibration factor until the XTreme-EFIS OAT matches that of a precision thermometer. Calibration can only be done in Celcius (°C).

### 4.6 EMS Setup

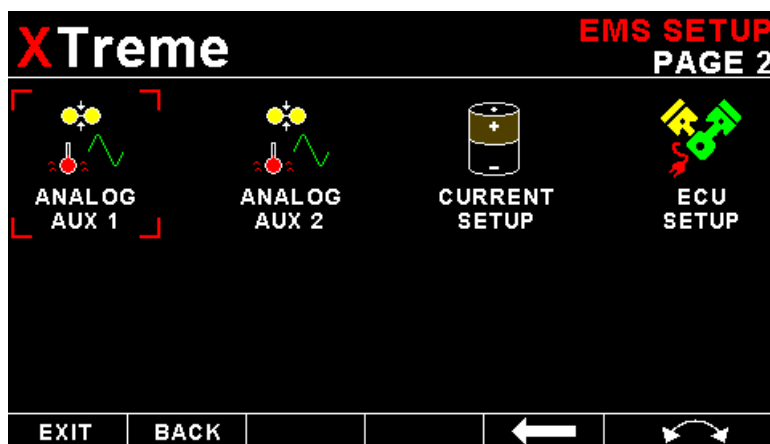
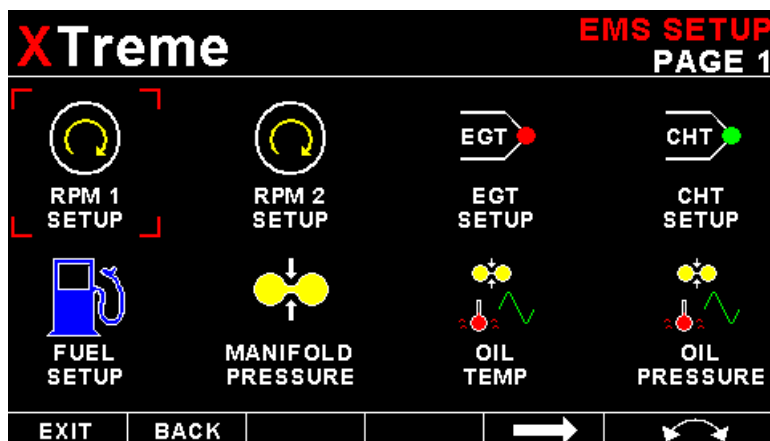

### 4.6.1 RPM 1 Setup

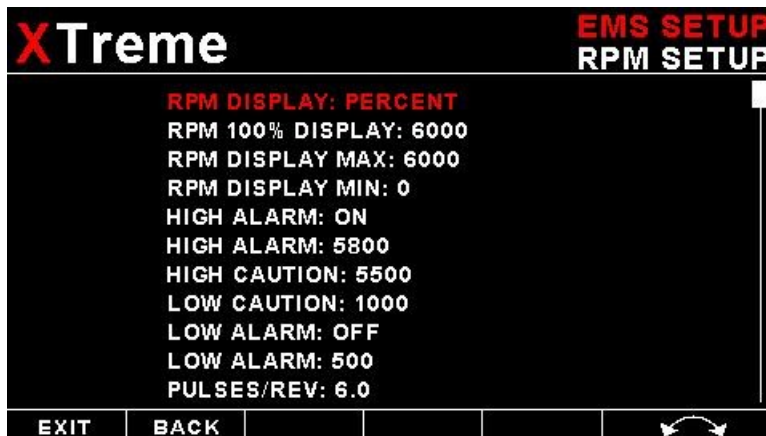

**RPM DISPLAY:**

Select if you want the RPM to be displayed in “RPM” or “PERCENT”. If you do not want any RPM information then set this parameter to “OFF”. If the RPM 2 is set to “RPM” or “PERCENT” then the engine RPM display will automatically be enabled.

**RPM 100% DISPLAY:**

Select the maximum value that you want the RPM to correlate to 100%.

**RPM DISPLAY MAX:**

Select the maximum RPM that you want the RPM dial to show. This can give you increased display resolution.

**RPM DISPLAY MIN:**

Select the minimum RPM that you want the RPM dial to show. This can give you increased display resolution.

**HIGH ALARM:**

This enables or disables the RPM high alarm.

**HIGH ALARM:**

Enter the RPM threshold for when the high alarm must be activated. Any RPM value above this value will activate the alarm.

**HIGH CAUTION:**

Enter the RPM value for the high caution. This is the lower value of the upper yellow band.

**LOW CAUTION:**

Enter the RPM value for the low caution. This is the upper value of the lower yellow band.

**LOW ALARM:**

This enables or disables the RPM low alarm.

**LOW ALARM:**

Enter the RPM threshold for when the low alarm must be activated. Any RPM value below this value will activate the alarm.

***PULSES/REV:***

Enter the number of pulses per RPM. For engines with an uneven number of cylinders like three cylinder four stroke engines you can enter values containing fractions (usually 1.5 in this example). Most four stroke engines would generate one pulse for every two revolutions per cylinder. A four cylinder automotive four stroke engine would thus generate 2 pulses per revolution. A typical Rotax DCDI two stroke engine would generate 6 pulses per revolution. The well known Rotax 912/914 engine generates one pulse per revolution.

***INCREMENT:***

Select the step size between successive RPM values eg. if the RPM value is 4003 RPM and the "*RPM RESOLUTION*" is 5 then the actual value shown is 4005 RPM.

***LABEL:***

Enter a label to suit your RPM 1 channel so you can identify it easily.

### 4.6.2 RPM 2 Setup

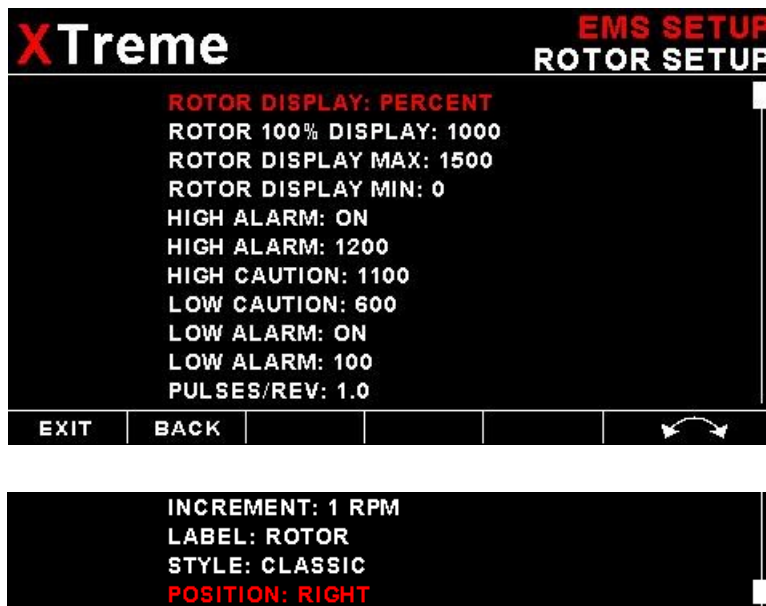

**RPM DISPLAY:**

Select if you want the RPM 2 to be displayed in “RPM” or “PERCENT” .If you do not want any RPM 2 information then set this parameter to off. If the RPM 2 is set to "RPM" or "PERCENT" then the RPM 1 display will automatically be enabled.

**RPM 100% DISPLAY:**

Select the maximum value that you want the RPM to correlate to 100%.

**HIGH ALARM:**

This enables or disables the RPM high alarm.

**HIGH ALARM:**

Enter the RPM threshold for when the high alarm must be activated. Any RPM value above this value will activate the alarm.

**HIGH CAUTION:**

Enter the RPM value for the high caution. This is the lower value of the upper yellow band.

**LOW CAUTION:**

Enter the RPM value for the low caution. This is the upper value of the lower yellow band.

**LOW ALARM:**

This enables or disables the low alarm.

**LOW ALARM:**

Enter the RPM threshold for when the low alarm must be activated. Any RPM value below this value will activate the alarm.

**PULSES/REV:**

Enter the number of pulses per RPM.

**INCREMENT:**

Select the step size between successive RPM values eg. if the RPM value is 403 RPM and the “RESOLUTION” is 5 then the actual value shown is 405 RPM.



**LABEL:**

Enter a label to suit your RPM 2 channel so you can identify it easily.

**STYLE:**

Select this menu option to change the graphic style of the RPM 1 and RPM 2 display.

ARC Display

CLASSIC Display

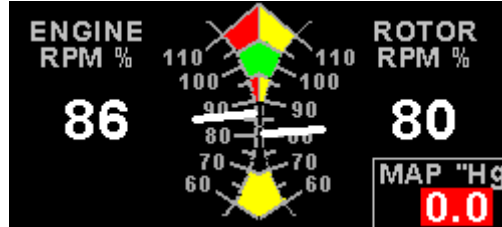

**POSITION:**

Select which side of the analog dials the RPM 1 / RPM 2 must be displayed on.

### 4.6.3 EGT/CHT Setup

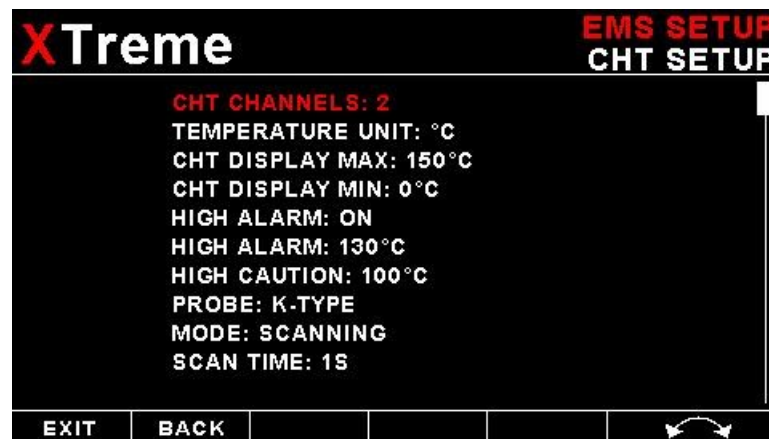
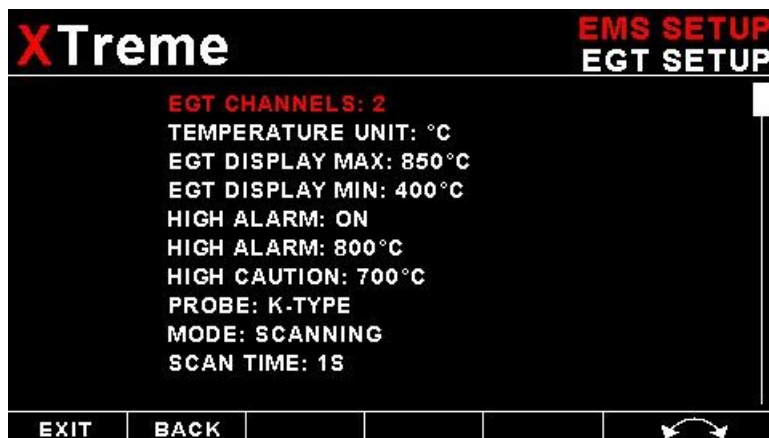

**EGT / CHT CHANNELS:**

Select the number of EGT or CHT channels you want to use. Choices are from 1 to 12. The temperature display will configure itself to make best possible use of the available display size. Please note that the minimum number of EGT & CHT channels that can be displayed is 1 and the maximum number of EGT and CHT channels that can be displayed is 12.

**EGT / CHT DISPLAY MAX:**

Select the maximum temperature that you want the EGT / CHT bargraph to show. This can give you increased display resolution.

**EGT / CHT DISPLAY MIN:**

Select the minimum temperature that you want the EGT / CHT bargraph to show. This can give you increased display resolution.

**HIGH ALARM:**

This enables or disables the EGT / CHT high alarm.

**HIGH ALARM:**

Enter the temperature threshold for when the high alarm must be activated. Any temperature above this value will activate the alarm.

**HIGH CAUTION:**

Enter the temperature value for the high caution.

**PROBE:**

Select if you are using a K-type, J-type or E-type thermocouple probe for the EGT/CHT group. All probes supplied by MGL Avionics are K-Type. J-types are sometimes used with American made CHT probes. All EGT probes are K-type. E-type probes are seldom used.

**TEMPERATURE UNIT:**

Select whether you want the EGT / CHT temperature to be displayed in degrees Celsius (°C) or degrees Fahrenheit (°F).

**MODE:**

A selection between "HIGHEST" or "SCANNING" can be selected. If "HIGHEST" is selected then the current highest thermocouple temperature is displayed. If "SCANNING" is selected then the unit will cycle through each thermocouple at the time specified in "SCAN TIME".

**SCAN TIME:**

Specify the time that each of the channels must be displayed for. This menu option is only shown if "SCANNING" is selected for the display mode.

### 4.6.3.1 Special Rotax 912/914 probe mode

In this mode the RDAC AUX 1 and AUX 2 analog input channels become the Rotax CHT channel 1 and CHT channel 2 respectively. All CHT setups must still be done under the "CHT SETUP" menu.

The reason for using the NTC inputs is that the sensors Rotax use are standard NTC temperature probes and not of a thermocouple type.

### 4.6.4 Fuel Setup

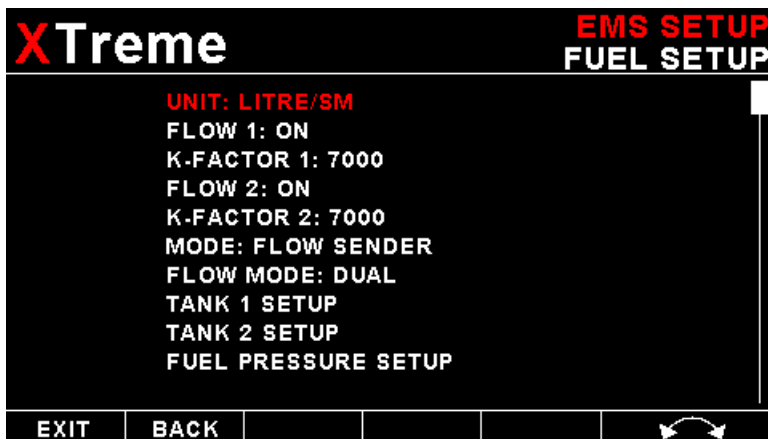

**UNIT:**

Select your desired units for distance and fuel quantity. The following options are available:

- L/sm: Liters and statute miles
- G/sm: U.S. Gallons and statute miles
- L/nm: Liters and nautical miles
- G/nm: U.S. Gallons and nautical miles
- L/km: Liters and kilometer
- G/km: U.S. Gallons and kilometers

**FLOW 1 / FLOW 2:**

This enables or disables the Flow 1 display.

**K-FACTOR 1 / K-FACTOR 2:**

The K-Factor is the number of pulses generated by the fuel flow sender for one liter of fuel. The dual range fuel flow sender supplied by MGL Avionics has a K-Factor of 7000 in the low flow mode (jet installed) and 1330 for the high flow mode (no jet installed). The Flowscan 201A-6 has a K-Factor of 8454. You can use the K-Factor to calibrate your fuel flow sender. See the RDAC manual for more details on how to calibrate and install the fuel flow sender.

**MODE:**

Select if you want to measure fuel flow using a fuel flow sender or by using fuel injectors.

**FLOW MODE:**

If both fuel flow senders are selected then select if they are operating on individual fuel tanks (dual) or if they are operating in a supply/return type fuel system (differential).

**TANK 1 SETUP / TANK 2 SETUP:**

Select this menu item to setup the fuel level for fuel tank 1 / fuel tank 2. See below for more details.

Fuel level setup. (Only tank 1 setup is shown, follow the same steps for tank 2 setup)

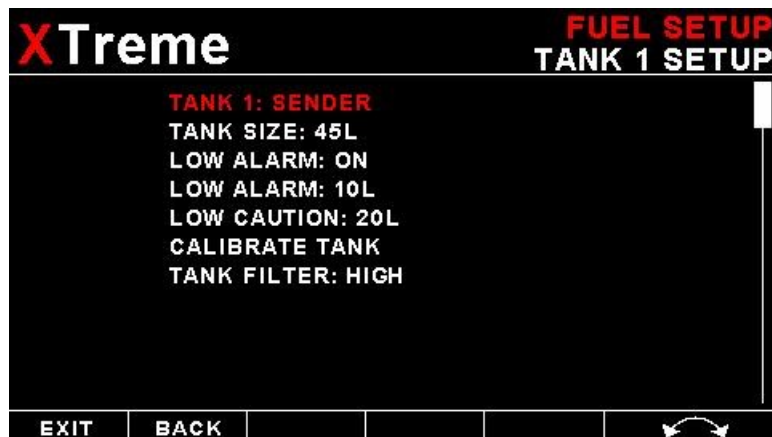

#### **TANK 1 / TANK 2:**

Select if the fuel tank has a physical fuel level sender connected to it or if the XTreme-EFIS must use a calculation based virtual fuel tank. If you do not want any fuel level information then set this parameter to off.

#### **TANK SIZE:**

Enter the size of the fuel tank in your system. It is recommended to choose a size that is slightly less than the actual size so you can compensate for sender inaccuracies and give you a measure of reserve fuel.

#### **LOW ALARM:**

This enables or disables the fuel level low alarm.

#### **LOW ALARM:**

Enter your desired minimum fuel value that you would like to trigger the fuel low alarm.

#### **LOW CAUTION:**

Enter the fuel level value for the low fuel caution.

#### **CALIBRATE TANK:**

The fuel level sender needs to be calibrated before it can be used with this system. The calibration allows the system to learn the shape of your tank as well as any errors your fuel level sender or installation has.

Regardless of your use of a fuel flow sender, you can install a fuel level sender into your fuel tank. These level senders are inexpensive and are available as after market replacement fittings from a car spares outlet.

Be aware that some makes of cheap level senders can prove troublesome, as the lever arms tend to be sticky. This prevents the floats from floating on the surface of the fuel at all times. As a consequence, this will lead to incorrect fuel level indication.

## Adjusting calibration points automatically

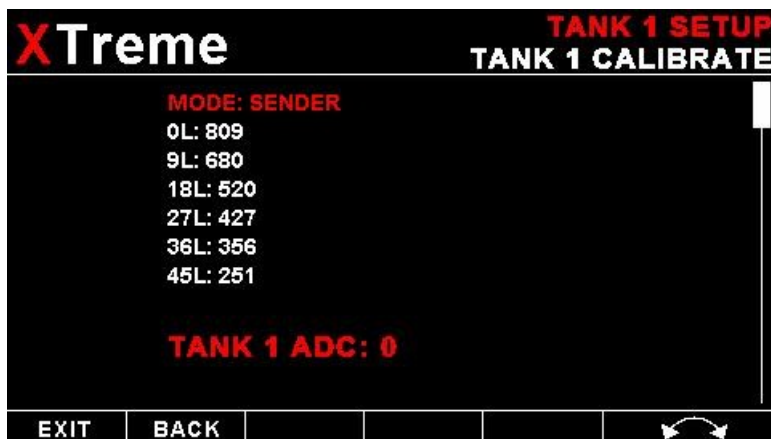

Select “SENDER” for the “MODE” menu item. Once you have installed a fuel level sender into your tank, make sure the float can travel all the way from empty to full position without hindrance of any kind. The calibration procedure should be carried out with your aircraft in flight attitude. This means you need to lift the tail if you have a tail-dragger or lift the nose wheel if you have a weightshift trike.

## Calibration procedure

- Start the calibration procedure with an empty tank.
- Add five liters of fuel (our reserve quantity) using a suitable measure. Make sure the measure is suitably accurate. This is now the “level sender reading at 0 Lt” position. Move the highlight to this position and wait until the sender reading has stabilized (You will see the sender reading at the top line). This could take up to a minute so have patience.

ENSURE THAT THE FLOAT IS NOT SUBMERGED AND IS FLOATING ON TOP OF THE FUEL LEVEL.

Should this number not react to changes of your level sender position, then you have a problem. Please check your wiring according to the installation section of this manual. You should expect the number to change in the region of at least 20 to 60 counts per calibration position. If the number does not change with fuel level or only changes a very small amount – check your installation. Something is not right!

- If you see the number changing then everything is well. Once it has stabilized and the highlight is on the 0 L position, press the rotary control to transfer the reading from the sender to the calibration point.
- Now you are ready for the next step. Add the required amount of fuel to get to the next level (In our case 9 Lt – this is 20% tank capacity). Once done, wait for the reading to stabilize and press the rotary control again after you have moved the highlight to the “9 L” position.
- Proceed in a similar manner until you have reached the last calibration position at 100% tank capacity.

You are done!

The instrument uses the 6 calibration points to work out a correction curve that takes into account the tolerances of your fuel level sender and the shape of your fuel tank. This results in an incredibly accurate and usable fuel level display that far exceeds that available from ordinary dial type gauges.

## Adjusting calibration points manually



You may want to set individual calibration points manually. For example you may find that your fuel level is over reading at a specific fuel level. Correcting the tank level reading for this area can be simply done by adjusting the calibration point. You can do this by moving the float level with your hands to the desired position and then performing the calibration as outlined above, or you can use the manual option.

Select "MANUAL" for the "MODE" menu item. Then highlight the point you want to change manually and press the rotary control. Use the rotary control to adjust the value. Press the rotary control when done.

**Note:** The calibration positions may be edited by using the rotary control. This allows you, in theory, to copy calibration settings from one instrument to another. We however recommend that you do go through the calibration procedure even if the two aircraft are identical in all respects. Tolerances do exist and the calibration cancels these out. Accurate fuel level displays are a vital safety factor for an aircraft and a very useful feature for peace of mind during cross county flights.

## Notes on Slope error



Sender value is a value determined by the Xtreme-EFIS. It is used to calculate fuel level, fuel endurance estimate and current range estimate. The fuel tank setup sender value can either increase in value as fuel is added or decrease in value if fuel is added. This is dependent on the type of fuel level sender used. However should the second reading be larger than the first reading all readings will have to be larger than the previous readings. Likewise should the second reading be smaller than the first reading all readings will have to be smaller than the previous reading.

If this is not the case the wording "SLOPE ERROR" will be displayed. This could happen when fuel was removed instead of added between steps, no fuel was added between steps or when the fuel level sender was moved in the wrong direction e.g. moving the fuel level sender manually when it is not inserted in to the fuel tank. Determine the cause of the error if you should get a slope error message. If you do not know the cause of your error it is best to start from scratch. It should be remembered that accuracy in the fuel tank calibration is extremely important to enable your XTreme-EFIS to display the correct data.

### TANK FILTER:

Select the damping factor for the fuel level. A selection of "NONE", "LOW", "MED" or "HIGH" can be made.

***Tank LITRE RESOLUTION:***

Select the resolution of the Litre unit. 1L or 0.1L



**FUEL PRESSURE SETUP: (MGL Avionics RDAC-XF / MAP Required)**

Select this menu item to setup the fuel pressure input.

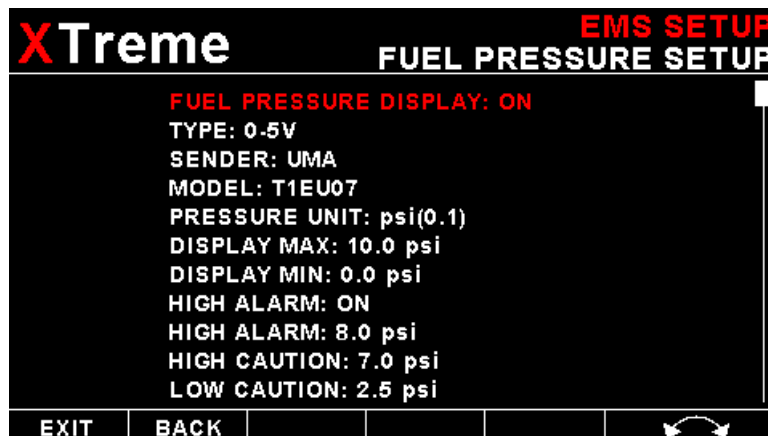

**FUEL PRESSURE DISPLAY:**

This enables or disables the fuel pressure display on the EMS display screen

**TYPE:**

Select if you are using a resistive, voltage or a current output pressure sender.

**If the “RESISTIVE” pressure sender is selected**

**SENDER:**

Select what type of resistive pressure sender you are using. Select “VDO” for VDO / resistive senders, “USER” for a custom sender.

**MODEL:**

Select which VDO pressure sender you are using. A selection between a VDO 2, 5 or 10 Bar can be selected.

**If the “VOLTAGE” pressure sender is selected**

**Sender:**

Select the type of voltage sender you are using. Select “UMA” for UMA senders, “0.5-4.5V” for voltage senders, or “USER” for a custom voltage sender.

**Model:**

For UMA senders select the UMA model number.

**If the “CURRENT” pressure sender is selected**

**Sender:**

Select the type of current sender you are using. Select “4-20mA” for Rotax 912/914 4-20mA sender or “USER” for a custom 4-20mA sender.

**Pressure @ 4mA:**

Enter the pressure specified at 4mA output.

**Pressure @ 20mA:**

Enter the pressure specified at 20mA output.

**Menu options for all sender types****If the "USER" pressure sender is selected****CALIBRATE SENDER:**

If the sender type is set to "USER", then use this menu option to calibrate your pressure sender. See section 4.4.9 for more information.

**PRESSURE UNIT:**

Select whether you want to display the pressure in Bar, PSI or PSI(0.1). The PSI(0.1) is for low range pressure senders e.g. UMA 7PSI.

**DISPLAY MAX:**

Select the maximum pressure that you want the oil pressure bargraph to show. This can give you increased display resolution.

**DISPLAY MIN:**

Select the minimum pressure that you want the oil pressure bargraph to . This can give you increased display resolution.

**HIGH ALARM:**

This enables or disables the pressure high alarm.

**HIGH ALARM:**

Enter the pressure threshold for when the high alarm must be activated. Any pressure above this value will activate the alarm.

**HIGH CAUTION:**

Enter the pressure value for the high caution. This is the lower value of the upper yellow band.

**LOW CAUTION:**

Enter the pressure value for the low caution. This is the upper value of the lower yellow band.

**LOW ALARM:**

This enables or disables the pressure low alarm.

**LOW ALARM:**

Enter the pressure threshold for when the low alarm must be activated. Any pressure below this value will activate the alarm.

### 4.6.5 Manifold Setup (MGL Avionics RDAC-XF MAP required)

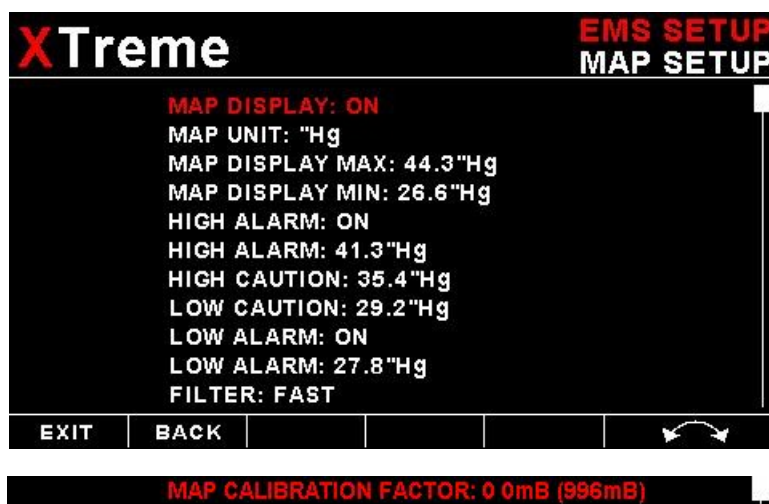

**MAP DISPLAY:**

This enables or disables the manifold pressure display on the EMS displays screens

**MAP UNIT:**

Select if you want the manifold pressure displayed in mB (millibars) or “Hg (inches of mercury).

**MAP DISPLAY MAX:**

Select the maximum pressure that you want the manifold bargraph in the EMS displays to show. This can give you increased display resolution.

**MAP DISPLAY MIN:**

Select the minimum pressure that you want the manifold bargraph in the EMS display to show. This can give you increased display resolution.

**HIGH ALARM:**

This enables or disables the manifold pressure high alarm.

**HIGH ALARM:**

Enter the pressure threshold for when the high alarm must be activated. Any pressure above this value will activate the alarm.

**HIGH CAUTION:**

Enter the pressure value for the high caution. This is the lower value of the upper yellow band.

**LOW CAUTION:**

Enter the pressure value for the low caution. This is the upper value of the lower yellow band.

**LOW ALARM:**

This enables or disables the manifold pressure low alarm.

**LOW ALARM:**

Enter the pressure threshold for when the low alarm must be activated. Any pressure below this value will activate the alarm.

***FILTER:***

This function can be used to select the signal filter time constant. Selections are "NONE", "FAST" or "SLOW". This selection influences the rate at which your manifold pressure can change its reading.

***MAP CALIBRATION FACTOR:***

The sender in the RDAC is shipped uncalibrated. To calibrate the manifold pressure, compare and adjust the calibration factor until the manifold reading is the same as the pressure value in brackets. The pressure value in brackets is the barometer reading built into the XTreme-EFIS. The manifold pressure can only be calibrated in mB.

### 4.6.6 Oil Temperature Setup

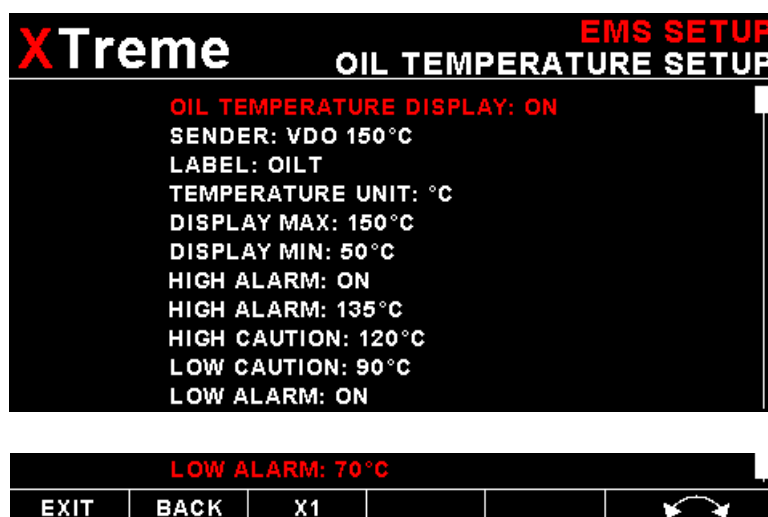

**OIL TEMPERATURE DISPLAY:**

This enables or disables the oil temperature display

**SENDER:**

Select what type of sender you are using.

Select "VDO 120C" or "VDO 150C" for a VDO resistive sender, "WESTACH" for Westach thermistor type senders, "MGL" for a MGL NTC resistive temperature sender, "LM335" for a MGL precision temperature sender or "USER" for a custom sender.

The XTreme-EFIS has a built in linearization curve for a standard 50°C to 150°C VDO resistive sender, Westach senders and the MGL NTC resistive sender.

**If the sender is set to "USER"**

**CALIBRATE SENDER:**

If the sender type is set to "USER", then use this menu option to calibrate your temperature sender. See section 4.4.9 for more information.

**If the sender type is set to "LM335"**

**CAL:**

If the sender type is set to LM335, then use this menu option to calibrate your LM335 precision temperature sender. If recalibration is required then adjust the value using the rotary control until the temperature matches the reference ambient temperature. Please note that the LM335 can only be calibrated in degrees Celsius irrespective if the XTreme-EFIS is setup to display temperature in Fahrenheit.

**Menu options for all sender types**

**LABEL:**

Enter a label to suit your temperature channel so you can identify it easily.

**TEMPERATURE UNIT:**

Select whether you want the temperature to be displayed in degrees Celsius (°C) or in degrees Fahrenheit (°F).

**DISPLAY MAX:**

Select the maximum temperature that you want the oil temperature bargraph to show. This can give you increased display resolution.

**DISPLAY MIN:**

Select the minimum temperature that you want the oil temperature bargraph to show. This can give you increased display resolution.

**HIGH ALARM:**

This enables or disables the temperature high alarm.

**HIGH ALARM:**

Enter the temperature threshold for when the high alarm must be activated. Any temperature above this value will activate the alarm.

**HIGH CAUTION:**

Enter the temperature value for the high caution. This is the lower value of the upper yellow band.

**LOW CAUTION:**

Enter the temperature value for the low caution. This is the upper value of the lower yellow band.

**LOW ALARM:**

This enables or disables the oil temperature low alarm.

**LOW ALARM:**

Enter the temperature threshold for when the low alarm must be activated. Any temperature below this value will activate the alarm.

### 4.6.7 Oil Pressure Setup



**XTreme**
**EMS SETUP**

**OIL PRESSURE SETUP**

**OIL PRESSURE DISPLAY: ON**

TYPE: RESISTIVE

SENDER: VDO

MODEL: 10 bar

LABEL: OILP

PRESSURE UNIT: bar

DISPLAY MAX: 10.0 bar

DISPLAY MIN: 0.0 bar

HIGH ALARM: ON

HIGH ALARM: 8.0 bar

HIGH CAUTION: 7.0 bar

LOW CAUTION: 2.5 bar

LOW ALARM: ON

**LOW ALARM: 1.5 bar**

EXIT
BACK
X0.1

**OIL PRESSURE DISPLAY:**

This enables or disables the oil pressure display

**TYPE:**

Select if you are using a resistive, voltage or current output pressure sender.

**If the “RESISTIVE” pressure sender is selected**

**SENDER:**

Select what type of resistive pressure sender you are using. Select “VDO” for VDO / resistive senders, “USER” for a custom sender.

**MODEL:**

Select which VDO pressure sender you are using. A selection between a VDO 2, 5 or 10 Bar can be selected.

**If the “VOLTAGE” pressure sender is selected**

**Sender:**

Select the type of voltage sender you are using. Select “UMA” for UMA senders, “0.5-4.5V” for voltage senders, or “USER” for a custom voltage sender.

**Model:**

For UMA senders select the UMA model number.

## If the “CURRENT” pressure sender is selected

### **Sender:**

Select the type of current sender you are using. Select “4-20mA” for Rotax 912/914 4-20mA sender or “USER” for a custom 4-20mA sender.

### **Pressure @ 4mA:**

Enter the pressure specified at 4mA output.

### **Pressure @ 20mA:**

Enter the pressure specified at 20mA output.

## Menu options for all sender types

### If the “USER” pressure sender is selected

#### **CALIBRATE SENDER:**

If the sender type is set to “USER”, then use this menu option to calibrate your pressure sender. See section 4.4.9 for more information.

#### **LABEL:**

Enter a label to suit your pressure channel so you can identify it easily.

#### **PRESSURE UNIT:**

Select whether you want to display the pressure in Bar, PSI or PSI(0.1). The PSI(0.1) is for low range pressure senders e.g. UMA 7PSI.

#### **DISPLAY MAX:**

Select the maximum pressure that you want the oil pressure bargraph to show. This can give you increased display resolution.

#### **DISPLAY MIN:**

Select the minimum pressure that you want the oil pressure bargraph to . This can give you increased display resolution.

#### **LOW ALARM:**

This enables or disables the pressure low alarm.

#### **LOW ALARM:**

Enter the pressure threshold for when the low alarm must be activated. Any pressure below this value will activate the alarm.

#### **LOW CAUTION:**

Enter the pressure value for the low caution. This is the upper value of the lower yellow band.

#### **HIGH CAUTION:**

Enter the pressure value for the high caution. This is the lower value of the upper yellow band.

#### **HIGH ALARM:**

This enables or disables the pressure high alarm.

#### **HIGH ALARM:**

Enter the pressure threshold for when the high alarm must be activated. Any pressure above this value will activate the alarm.



### 4.6.8 Auxiliary Analog 1, 2 Setup



The analog AUX 1,2 channels on the RDAC are general purpose channels that can be used for pressure, temperature, current or as a Generic analog input.

**FUNCTION:**

Select the function for the analog channel. Options are "PRESSURE", "TEMPERATURE", "CURRENT", "GENERIC" or "OFF".

If the "PRESSURE" mode is selected:

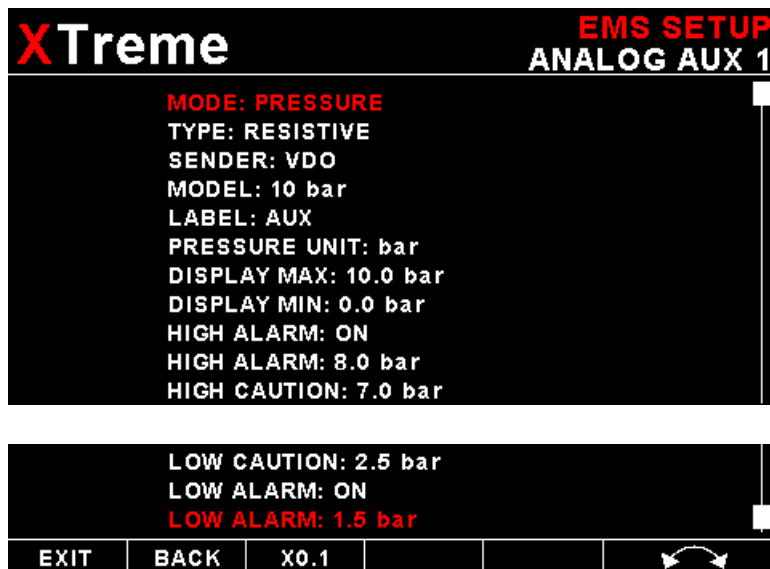

**TYPE:**

Select if you are using a resistive, 4-20mA or 0-5V output pressure sender.

If the "RESISTIVE" pressure sender is selected

**SENDER:**

Select what type of resistive pressure sender you are using. Select "VDO" for VDO / resistive senders, "USER" for a custom sender.

**MODEL:**

Select which VDO pressure sender you are using. A selection between a VDO 2, 5 or 10 Bar can be selected.

## If the “VOLTAGE” pressure sender is selected

### **Sender:**

Select the type of voltage sender you are using. Select “UMA” for UMA senders, “0.5-4.5V” for voltage senders, or “USER” for a custom voltage sender.

### **Model:**

For UMA senders select the UMA model number.

## If the “CURRENT” pressure sender is selected

### **Sender:**

Select the type of current sender you are using. Select “4-20mA” for Rotax 912/914 4-20mA sender or “USER” for a custom 4-20mA sender.

### **Pressure @ 4mA:**

Enter the pressure specified at 4mA output.

### **Pressure @ 20mA:**

Enter the pressure specified at 20mA output.

## Menu options for all sender types

### If the “USER” pressure sender is selected

#### **CALIBRATE SENDER:**

If the sender type is set to “USER”, then use this menu option to calibrate your pressure sender. See section 4.6.9 for more information.

#### **LABEL:**

Enter a label to suit your temperature channel so you can identify it easily.

#### **PRESSURE UNIT:**

Select whether you want to display the pressure in Bar, PSI or PSI(0.1). The PSI(0.1) is for low range pressure senders e.g. UMA 7PSI.

#### **DISPLAY MAX:**

Select the maximum pressure that you want the bargraph to show. This can give you increased display resolution.

#### **DISPLAY MIN:**

Select the minimum pressure that you want the bargraph to show. This can give you increased display resolution.

#### **HIGH ALARM:**

This enables or disables the pressure high alarm.

#### **HIGH ALARM:**

Enter the pressure threshold for when the high alarm must be activated. Any pressure above this value will activate the alarm.

**HIGH CAUTION:**

Enter the pressure value for the high caution. This is the lower value of the upper yellow band.

**LOW CAUTION:**

Enter the pressure value for the low caution. This is the upper value of the lower yellow band.

**LOW ALARM:**

This enables or disables the pressure low alarm.

**LOW ALARM:**

Enter the pressure threshold for when the low alarm must be activated. Any pressure below this value will activate the alarm.

**If the “TEMPERATURE” mode is selected:**

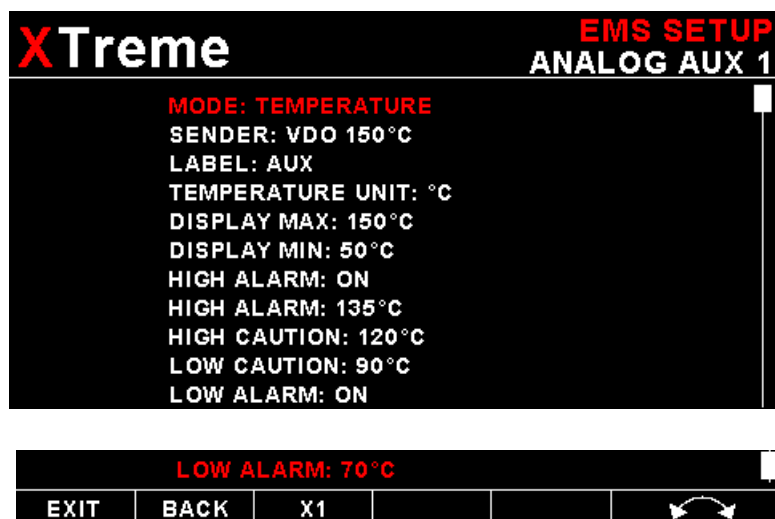

**SENDER:**

Select what type of sender you are using.

Select “VDO” for a VDO resistive sender, “WESTACH” for Westach thermistor type senders, “MGL” for a MGL NTC resistive temperature sender, “LM335” for a MGL precision temperature sender or “USER” for a custom sender.

The XTreme-EFIS has a built in linearization curve for a standard 50°C to 150°C VDO resistive sender, Westach senders and the MGL NTC resistive sender.

**If the sender type is set to “USER”**

**CALIBRATE SENDER:**

If the sender type is set to “USER”, then use this menu option to calibrate your pressure sender. See section 4.6.9 for more information.

**If the sender type is set to “LM335”**

**CAL:**

If the sender type is set to LM335, then use this menu option to calibrate your LM335 precision temperature sender. If recalibration is required then adjust the value using the rotary control until the temperature matches the reference ambient temperature. Please note that the LM335 can only be calibrated in degrees Celsius irrespective if the XTreme is setup to display temperature in Fahrenheit.

## Menu options for all sender types

### **LABEL:**

Enter a label to suit your temperature channel so you can identify it easily.

### **TEMPERATURE UNIT:**

Select whether you want the temperature to be displayed in degrees Celcius (°C) or in degrees Fahrenheit (°F).

### **DISPLAY MAX:**

Select the maximum temperature that you want the bargraph to show. This can give you increased display resolution.

### **DISPLAY MIN:**

Select the minimum temperature that you want the bargraph to show. This can give you increased display resolution.

### **HIGH ALARM:**

This enables or disables the temperature high alarm.

### **HIGH ALARM:**

Enter the temperature threshold for when the high alarm must be activated. Any temperature above this value will activate the alarm.

### **HIGH CAUTION:**

Enter the temperature value for the high caution. This is the lower value of the upper yellow band.

### **LOW CAUTION:**

Enter the temperature value for the low caution. This is the upper value of the lower yellow band.

### **LOW ALARM:**

This enables or disables the temperature low alarm.

### **LOW ALARM:**

Enter the temperature threshold for when the low alarm must be activated. Any temperature below this value will activate the alarm.

## 4.6.9 Calibrating the user defined Pressure, Temperature and Generic input Senders

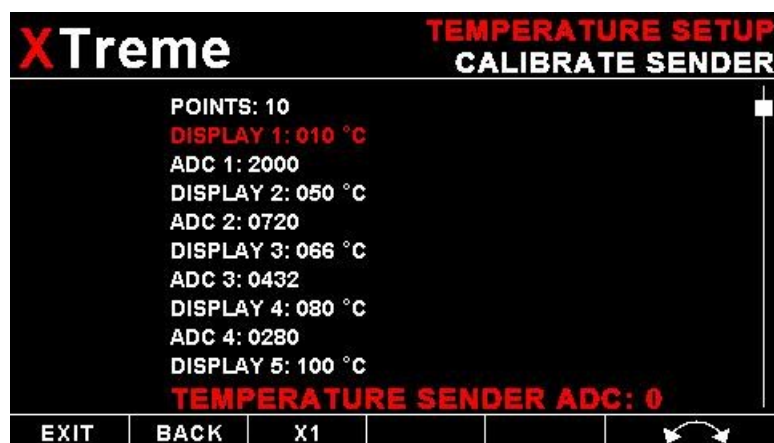

1. Enter the number of points that you want to calibrate.
2. Enter the display reading that you want to show when the sender is at that actual display reading.
3. Enter the ADC (analog to digital converter) reading that corresponds to this display reading. The ADC reading is shown at the bottom of the display if you are applying the actual stimulus from the temperature or pressure sender. You can also manually enter this value if the ADC value is known or pre-calculated.
4. Continue entering display and ADC values until all the points have been entered.
5. Verify the above calibration by checking the temperature/pressure display versus the actual applied sender stimulus.

If the “*CURRENT*” mode is selected: (MGL Avionics Closed Loop Current Sensor required)

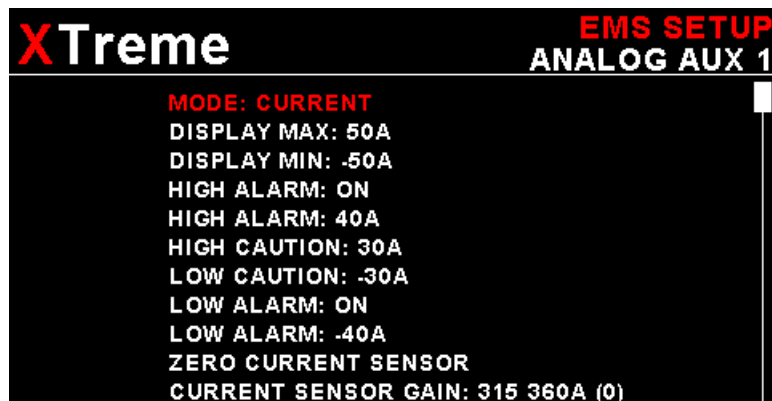

***DISPLAY MAX:***

Select the maximum current that you want the bargraph to show. This can give you increased display resolution.

***DISPLAY MIN:***

Select the minimum current that you want the bargraph to show. This can give you increased display resolution.

***HIGH ALARM:***

This enables or disables the current high alarm.

***HIGH ALARM:***

Enter the current threshold for when the high alarm must be activated. Any current above this value will activate the alarm.

***HIGH CAUTION:***

Enter the current value for the high caution. This is the lower value of the upper yellow band.

***LOW CAUTION:***

Enter the current value for the low caution. This is the upper value of the lower yellow band.

***LOW ALARM:***

This enables or disables the current low alarm.

***LOW ALARM:***

Enter the current threshold for when the low alarm must be activated. Any current below this value will activate the alarm.

***ZERO CURRENT SENSOR:***

Select this function to indicate to the XTreme-EFIS that zero current is flowing through the MGL Avionics Closed Loop Current sensor. This is best done with the MGL Closed Loop Current sensor disconnected from the main current supplying conductor.

***CURRENT SPAN CALIBRATION:***

Adjust the gain factor until the current is reading correctly. It will be best if a multimeter can be inserted in series with the current supplying conductor and the gain calibration adjusted until the XTreme-EFIS matches that of the multimeter. Please see the MGL Avionics Closed Loop Current Sensor documentation for more information.

If the “*GENERIC*” mode is selected:

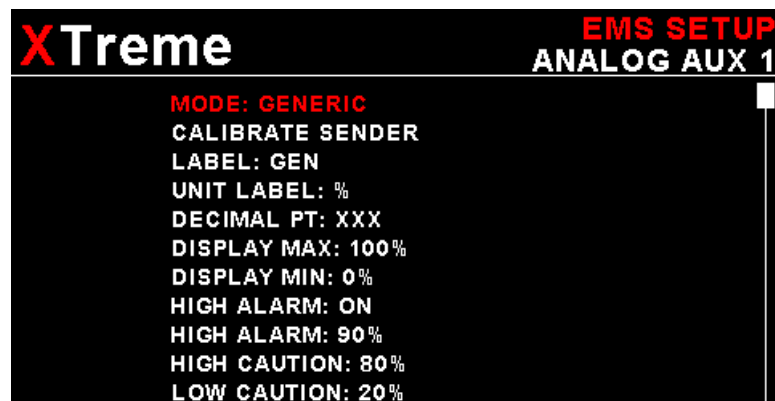

***CALIBRATE SENDER:***

Use this menu option to calibrate your generic analog input sender. See section 4.6.9 for more information.

***LABEL:***

Enter a label to suit your generic analog input channel so you can identify it easily.

***UNIT LABEL:***

Enter a unit label to suit your generic analog input channel.

***DECIMAL POINT:***

Enter the display decimal point position.

***DISPLAY MAX:***

Select the maximum input that you want the bargraph to show. This can give you increased display resolution.

***DISPLAY MIN:***

Select the minimum input that you want the bargraph to show. This can give you increased display resolution.

***HIGH ALARM:***

This enables or disables the high alarm.

***HIGH ALARM:***

Enter the threshold for when the high alarm must be activated. Any input above this value will activate the alarm.

***HIGH CAUTION:***

Enter the value for the high caution. This is the lower value of the upper yellow band.

***LOW CAUTION:***

Enter the value for the low caution. This is the upper value of the lower yellow band.

***LOW ALARM:***

This enables or disables the low alarm.

***LOW ALARM:***

Enter the input threshold for when the low alarm must be activated. Any temperature below this value will activate the alarm.

### 4.6.10 Current Setup (MGL Avionics RDAC-XF / MAP / RDAC-XG required)

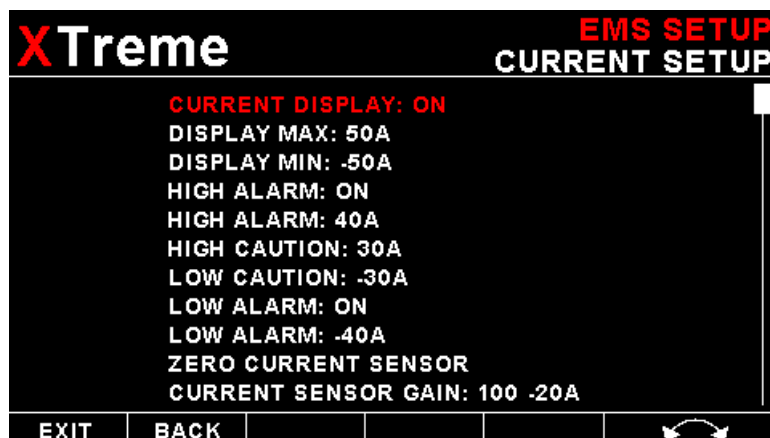

These menu options is only used if you have a MGL Avionics RDAC-XF / MAP / RDAC-XG and MGL Avionics closed loop current sensor.

**CURRENT DISPLAY:**

Select to enable or disable the current bar graph.

**DISPLAY MAX:**

Select the maximum current that you want the bargraph to show. This can give you increased display resolution.

**DISPLAY MIN:**

Select the minimum current that you want the bargraph to show. This can give you increased display resolution.

**HIGH ALARM:**

This enables or disables the current high alarm.

**HIGH ALARM:**

Enter the current threshold for when the high alarm must be activated. Any current above this value will activate the alarm.

**HIGH CAUTION:**

Enter the current value for the high caution. This is the lower value of the upper yellow band.

**LOW CAUTION:**

Enter the current value for the low caution. This is the upper value of the lower yellow band.

**LOW ALARM:**

This enables or disables the current low alarm.

**LOW ALARM:**

Enter the current threshold for when the low alarm must be activated. Any current below this value will activate the alarm.

**ZERO CURRENT SENSOR:**

Select this function to indicate to the XTreme-EFIS that zero current is flowing through the MGL Avionics Closed Loop Current sensor. This is best done with the MGL Closed Loop Current sensor disconnected from the main current supplying conductor.

***CURRENT SPAN CALIBRATION:***

Adjust the gain factor until the current is reading correctly. It will be best if a multimeter can be inserted in series with the current supplying conductor and the gain calibration adjusted until the XTreme-EFIS matches that of the multimeter. Please see the MGL Avionics Closed Loop Current Sensor documentation for more information.



### 4.6.11 ECU Setup

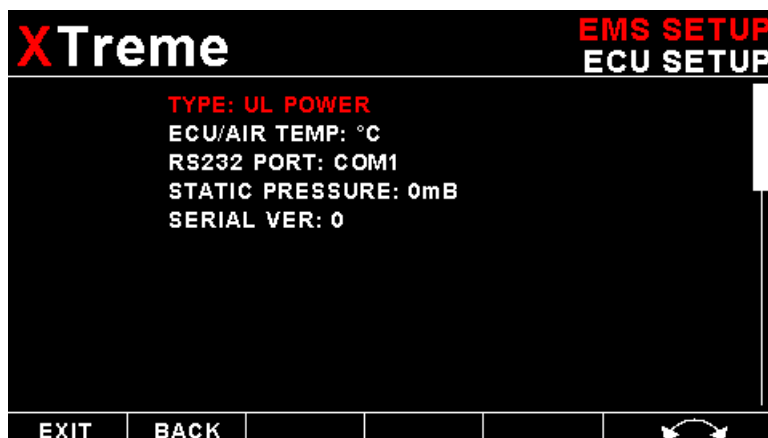

**Type:**

Select the ECU that is connected to the XTreme-EFIS. Select “NONE” for standard functionality, “ROTAX 912is” or “UL POWER”.

#### 4.6.11.1 ROTAX 912IS Setup

The Rotax 912iS can be connected to the XTreme-EFIS either by direct connection or by using the MGL Avionics RDAC CAN 912iS.

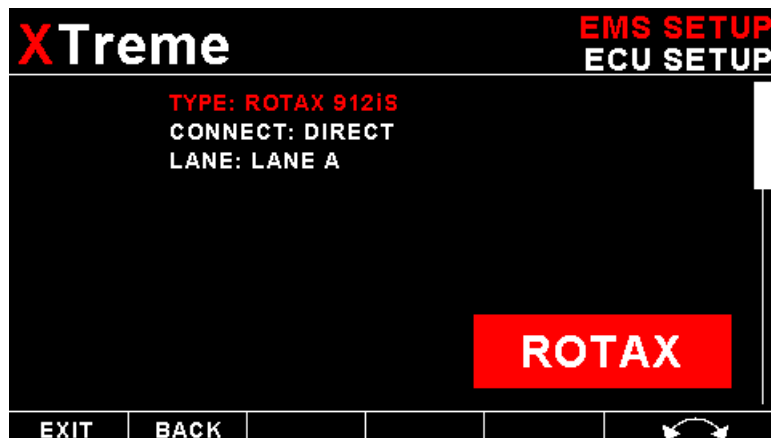

**Connect:**

Select if the Rotax 912iS ECU is connected to the XTreme-EFIS by direct connection or by using the MGL Avionics RDAC CAN 912iS.

**Lane: (Direct connection only)**

Select the lane that you want the data to be displayed from.

The Rotax 912iS ECU Oil temperature is mapped to the XTreme-EFIS Oil Temp Setup, Rotax 912iS ECU Oil Pressure to the Oil Pressure Setup and the Rotax 912iS ECU Coolant temperature to the XTreme-EFIS Coolant Temp Setup. These channels need to be setup accordingly

The Rotax ECU transmits various status messages. These can be observed in the Rotax ECU status and Rotax ECU faults main display pages,

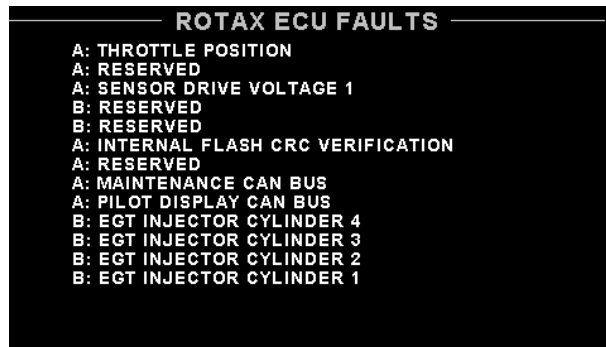
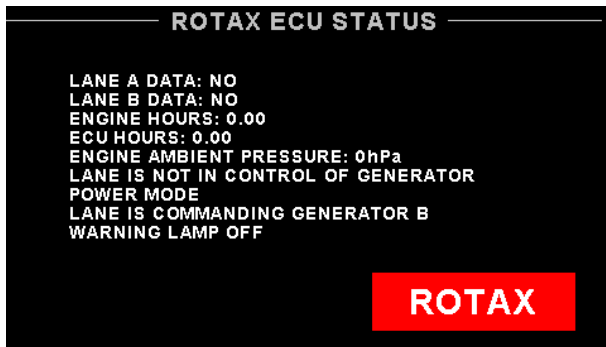

**Rotax 912iS Direct Connection**

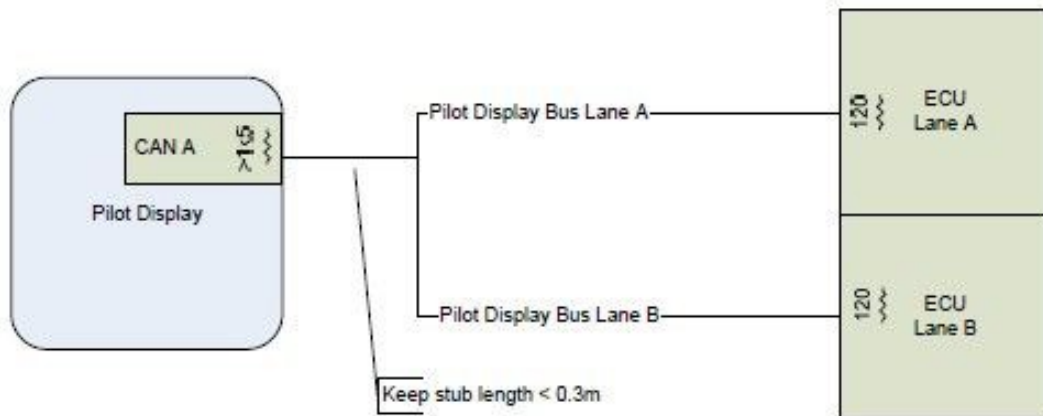

As shown on this diagram, connect the CAN bus ECU lanes A and B together and then connect to the XTreme-EFIS CAN inputs.

Do NOT add CAN termination resistors to this connection as both ECUs have these built in.

## **RDAC CAN Rotax 912iS Connection**

The XTreme-EFIS must be setup as follows:

**RPM 1:**

PULSES/REV: 1.0

**Fuel Flow:**

K-FACTOR 1: 7000  
MODE: FLOW SENDER

**Manifold Air Pressure:**

MAP CALIBRATION FACTOR: 0

**Oil Pressure:**

TYPE: RESISTIVE  
SENDER: USER  
CALIBRATE SENDER:  
POINTS: 2  
DISPLAY 1: 0.0 bar  
ADC 1: 0000  
DISPLAY 2: 10.0 bar  
ADC 2: 4095

**Oil Temperature:**

SENDER: LM335  
CAL: 0

**Coolant Temperature:**

This is remapped to ANALOG AUX1  
FUNCTION: TEMPERATURE  
SENDER: LM335  
CAL: 0

**EGT 1,2,3,4**

EGT CHANNELS: 4

**Throttle Position:**

0-100%. This can be viewed on the main display page

**Engine Ambient Pressure:**

This can be viewed on the Rotax ECU status page

**Fuel Level senders:**

This is setup as normal in the fuel setup menu

**Fuel pressure sender:**

This is setup as normal in the fuel setup menu

**DC current input:**

This is setup as normal in the current setup menu.



Please see the RDAC-CAN documentation for installation and usage.

**Rotax 912iS recommended settings:****Engine RPM:**

0 to 1500 RPM: Red  
1500 to 1800 RPM: Yellow  
1800 to 5500 RPM: Green  
>5800 RPM: Red

**MAP:**

0 to 200 mBar: Yellow  
200 to 1100 mBar: Green  
1100 to 1150 mBar: Yellow  
>1150 mBar: Red

**Oil Pressure:**

0 to 1.5 Bar: Red  
1.5 to 3.0 Bar: Yellow  
3.0 to 5.0 Bar: Green  
5.0 to 7.0 Bar: Yellow  
>7 Bar: Red

**Oil Temperature:**

<50 °C: Yellow  
50 to 110 °C: Green  
110 to 130 °C: Yellow  
>130 °C: Red

**Fuel Pressure:**

0 to 2.6 Bar: Red  
2.6 to 2.7 Bar: Yellow  
2.7 to 3.5 Bar: Green  
3.5 to 3.8 Bar: Yellow  
>3.8 Bar: Red

**Coolant Temperature:**

<50 °C: Yellow  
50 to 110 °C: Green  
110 to 120 °C: Yellow  
>120 °C: Red

**EGT Temperature:**

<900°C: Green  
900 to 950 °C: Yellow  
>950 °C: Red

### 4.6.11.2 ULPower ECU Setup

Connect the ULPower ECU to the XTreme-EFIS COM 1 or COM 2 serial port. The MGL Avionics RDAC can be used to measure CHT, EGT and MAP. The XTreme-EFIS also supports the ULPower Aux box.

**ECU/AIR TEMP:**

Select whether you want the temperature to be displayed in degrees Celcius (°C) or in degrees Fahrenheit (°F).

**RS232 PORT:**

Select which XTreme-EFIS serial port that the ULPower ECU is connected to.

### ULPower display screen

A dedicated display screen will be shown when the ULPower is selected for the ECU type.

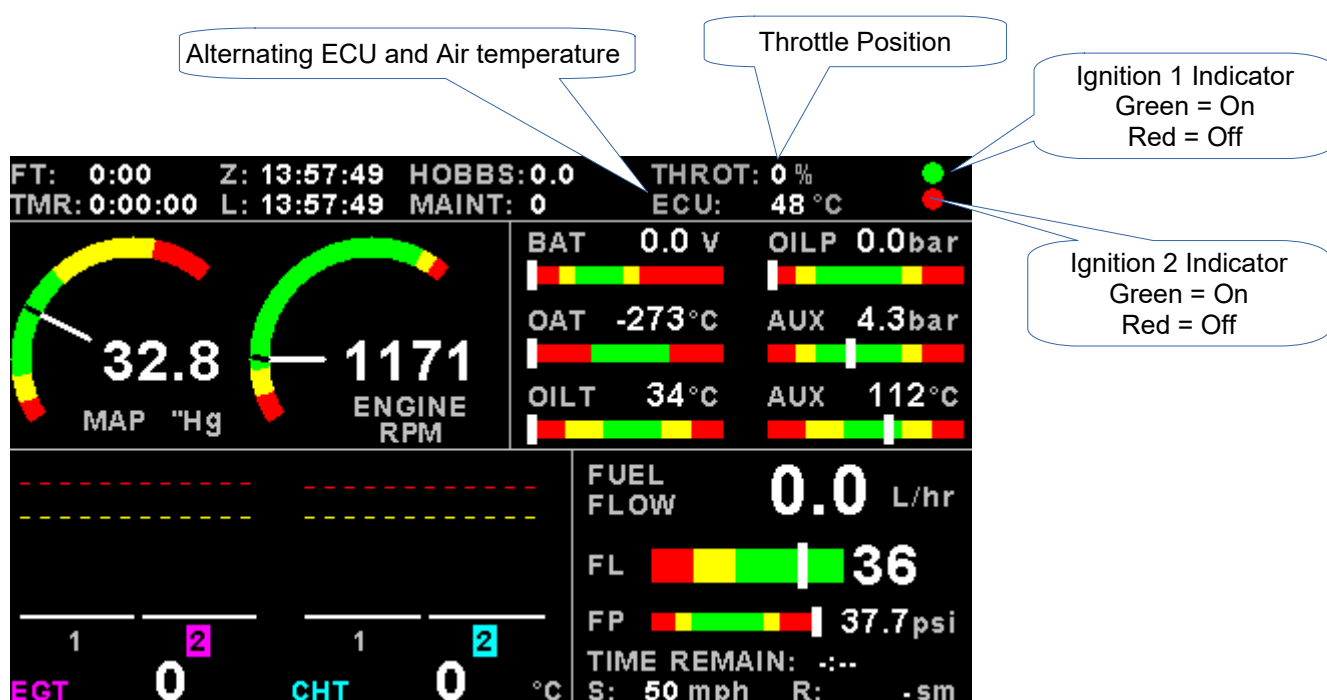

**Warning Messages from the ULPower ECU:**

**ECU COMMS ERROR**

The ECU COMMS ERROR message is shown if there is no communication received from the ULPower ECU.

**AIR TEMP SENSOR FAULT**

**THROTTLE POSITION SENSOR FAULT**

**MAP SENSOR FAULT****OIL TEMP SENSOR FAULT****POS-/SYNC SENSOR FAULT****ULPower recommended settings:**

**Oil Pressure:** max 8 bar (115psi) - normal 2 to 5 bar (30 – 75 psi) above 2000rpm - minimum 0.7 bar

**Oil Temperature:** Max 120°C (248°F) - Min 50°C (122°F) - Normal between 80°C and 100 °C (175°F – 212°F)

**Fuel Pressure:** max 3.8 bar (55psi) - normal 3 bar (43,5 psi) - minimum 2.4 bar (35 psi)

**MAP:** Max 1.1 bar (33 inch/kg) – Min. 0.3 bar (9 inch/kg)

**EGT:** max 860°C (1580°F) - Min. 400°C (700°F) - Normal between 700°C and 800°C (129°F – 1470°F)

**CHT:** max 180°C (356°F) - Max. continuous 160°C (320°F) - Min. 50°C (125°F)

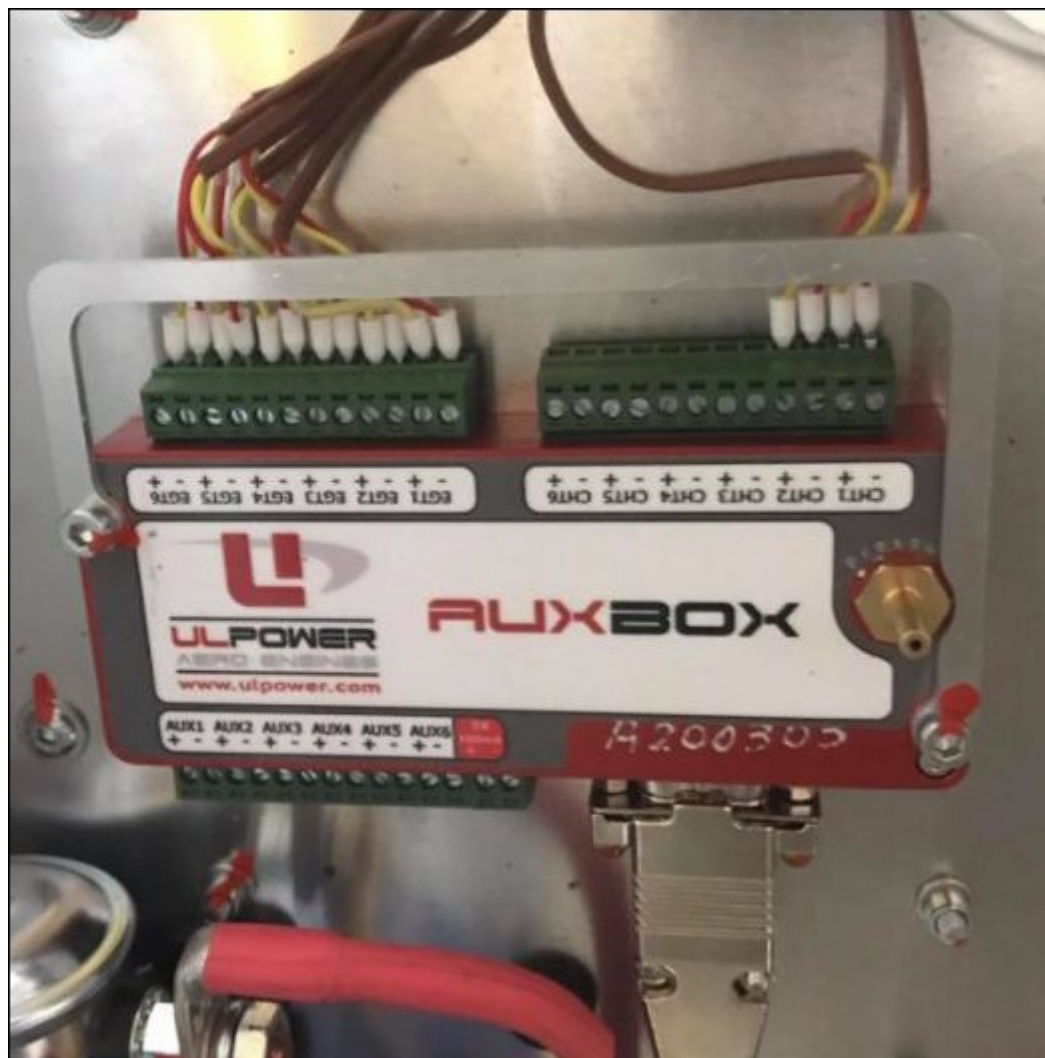

## 4.7 Compass Setup

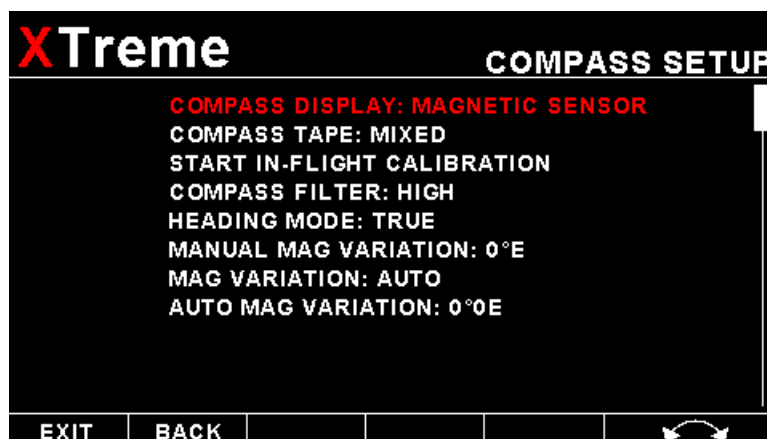

### COMPASS DISPLAY:

Select "MAGNETIC SENSOR" if you have a MGL Avionics SP6 compass sensor attached to the XTreme-EFIS. Select "GPS TRACK" if you want the compass displays to indicate GPS track (The compass display color will change to Magenta.)

### COMPASS TAPE:

Select the desired compass display mode. A selection from "MIXED", "CARDINAL" or "NUMERIC" can be selected.



"MIXED" shows headings as number in degrees except for the four major cardinal points which are shown as N,S, E and W.



"CARDINAL" shows headings as major and minor cardinal points: N, NNE, ENE, E, ESE, SSE, S, SSW, WSW, W, WNW, and NNW.



"NUMERIC" shows headings as numbers in degrees.

## In-Flight calibration Procedure

Please see documentation supplied with the MGL Avionics SP-6 for more information.

Fly the aircraft in safe area where you can perform random banked turns. Do not exceed the safety limits of the aircraft during the calibration flight.

Start the calibration in the Compass setup menu by selecting "START IN-FLIGHT CALIBRATION". The XTreme-EFIS will display the compass calibration screen. You should see the compass heading change to "111" to confirm that calibration has started.

**COMPASS  
CALIBRATION****COUNT: 0****FIT: 0.0%**

Fly a number of banked 180 or 360 degree turns at different bank angles - i.e. shallow, medium and steep turns. Try to add many different pitch attitudes in various orientations relative to the field direction. It does not matter in what order you fly the maneuvers. A typical, good calibration tends to take 5-10 minutes of flight.

Do not activate any electrical equipment that creates large magnetic fields during the calibration process (for example starter motors, autopilot servos, landing lights etc). The heading starts reading **111** after you start calibration. After 36 initial samples have been collected this changes to **222**. This should take approximately one turn. Continue the flight while maneuvering until the heading starts reading normally. This happens once the SP-6 has collected 100 distinctly different magnetic samples. At this point the heading should start showing reasonable numbers. Continue the calibration flight, settling into straight and level at intervals on different headings and verify the heading readout against an ACCURATE reference. Continue the flight until you find heading errors that are within 1 to 2 degrees, about the limit one can reasonably expect.

When satisfied, end the calibration by selecting "END IN-FLIGHT CALIBRATION" in the compass calibration menu. This will save the calibration to permanent memory in the SP-6. Should you not be able to achieve a good heading readout, please locate the compass to a better location in the aircraft.

The XTreme-EFIS displays the calibration sample count and fit percentage during calibration. The sample count will count up to 150 after which new samples replace the oldest samples stored. The fit percentage is a value from 0% to 100%. The aim is to get to a value as close as possible to 100%. The fit starts displaying other than 0% after the first 36 samples. Fit values of 98% and higher are considered good. If you cannot achieve this you do not have a good installation location for your compass. You may still get reasonably good heading accuracy despite a lower fit. However, to ensure long term accuracy please consider locating the SP-6 in a better area in your aircraft.

If the readout decreases suddenly by a large amount (for example from 85% to 42%), this is typically caused by a strong time-variant magnetic field such as can be created by electrical equipment (motors, relays, current flow in cables). In such a case please either end and restart the calibration or continue the calibration flight until the fit error is acceptable again (the incorrect magnetic sample(s) will eventually be removed). It is advised to locate the interference source and either move this or the SP-6 to a better location in the aircraft.

**Note: should you move the SP-6 to a new location or fit new equipment close to the SP-6 you will have to perform the calibration again. There is no practical limit as to how many times you can perform and save a new calibration.**



**COMPASS FILTER:**

Select the filter factor for the compass heading. A selection of "NONE", "LOW", "MED" or "HIGH" can be made. This can improve the stability of the compass.

**HEADING MODE:**

Select if you want all heading related data to indicate true or magnetic north.

**MANUAL MAG VARIATION:**

This item allows the pilot to manually enter his local variation.

**MAG VARIATION:**

Select "AUTO" to allow the XTreme-EFIS to automatically calculate the local variation or "MANUAL" for manual local variation input.

**AUTO MAG VARIATION:**

This item displays the calculated local magnetic variation. The XTreme-EFIS will calculate the local variation every 10 minutes if a valid 2D or 3D GPS fix is obtained.

**Please note:** The XTreme-EFIS will only use the automatically calculated variation if a valid 2D or 3D GPS fix is obtained otherwise it will use the manual local variation value. It is recommended to enter the local magnetic variation in case of GPS loss.

## 4.8 Horizon Setup

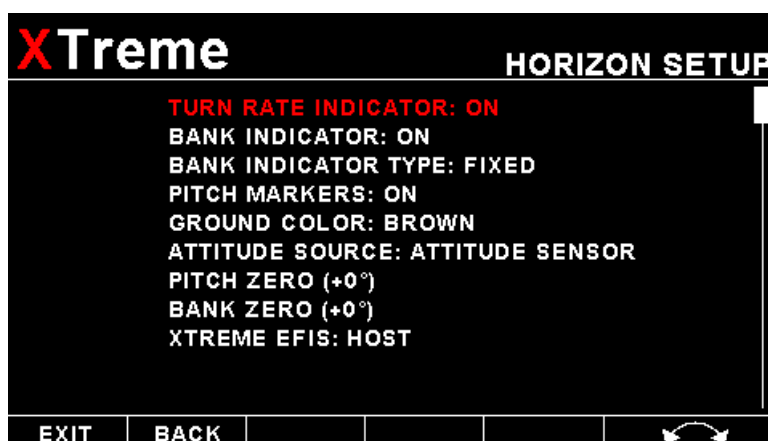

### **TURN RATE INDICATOR:**

This enables or disables the turn rate indicator on the EFIS and MFD displays.

### **BANK INDICATOR:**

This enables or disables the bank indicator markings on the EFIS and MFD displays.

### **BANK INDICATOR TYPE:**



Select whether the bank indicator markings are "MOVING" or are "FIXED" (default) The "FIXED" bank indicator has an clear arrow which moves to stay perpendicular with the horizon, the "MOVING" bank indicator rotates the scale around a stationary arrow.

### **PITCH MARKERS:**

This enables or disables the pitch markers on the EFIS and MFD displays.

### **GROUND COLOR:**

Select the color of the ground in the EFIS display. A selection between "BROWN" (default) or "GREEN" can be made.

### **ATTITUDE SOURCE:**

Select the source of the attitude indication for the EFIS display. Select "ATTITUDE SENSOR" for a MGL Avionics attitude sensor package, "GPS FLIGHT PATH" for a gps based attitude indication or "NONE" for a grey background EFIS display.

If the attitude source is set to "GPS FLIGHT PATH" the following must be considered:



The GPS Flight path feature uses a method to calculate bank and pitch angles from information obtained from the internal GPS receiver. This is no means a replacement for a real gyro based AHRS unit but is more intended as an informative / simulated display of the horizon.

This feature is only available using the internal GPS receiver due to the high update rates required by the internal calculations. The GPS Flight Path requires a 2D or 3D GPS fix. If a 2D GPS fix is obtained then the pitch angle uses the VSI instead of the vertical vector in determining the pitch angle. The GPS Flight Path is engaged only when the airspeed is greater then 20mph.

The GPS Flight Path can be used as a low cost artificial horizon display allowing the pilot to be able to have the look and feel of a real EFIS display without the additional cost of a AHRS sensor unit.

The text “GPS FLIGHT PATH NO ATTITUDE” is displayed when the GPS Flight Path is enabled. This cannot be removed from the display and reminds the pilot of the limitations thereof.

The GPS Flight Path is based on coordinated flight and it will display incorrect horizon information during unusual uncoordinated flight maneuvers.

## WARNING

This is no means a replacement for a real gyro based AHRS unit but is more intended as a informative / simulated display of the horizon. This is strictly not to be used for IMC/IFR flights. MGL Avionics or any of its distributors take no responsibility for the use of the GPS Flight Path feature and it is the sole responsibility of the pilot in command to familiarize themselves with the use and limitations of using such a technology.

### **PITCH ZERO:**

The pitch zero function must be performed with the AHRS perfectly level. The AHRS will refuse to perform this operation if the real pitch angle is greater than 10 degrees. Selecting the pitch zero function will zero the pitch, selecting it again will reset the pitch offset value to 0 degrees.

### **BANK ZERO:**

The bank zero function must be performed with the AHRS perfectly level. The AHRS will refuse to perform this operation if the real bank angle is greater than 10 degrees. Selecting the bank zero function will zero the bank, selecting it again will reset the bank offset value to 0 degrees.

### **XTREME EFIS:**

Select whether the Xtreme EFIS is a “HOST” (default) or “DEVICE” on the CAN bus. The Xtreme will transmit the CAN messages necessary for the MGL Avionics SP7 if it is set as the “HOST”. Only a single Xtreme EFIS must be set as the “HOST” when multiple Xtremes are connected on the same CAN bus.

## 4.9 GPS Setup

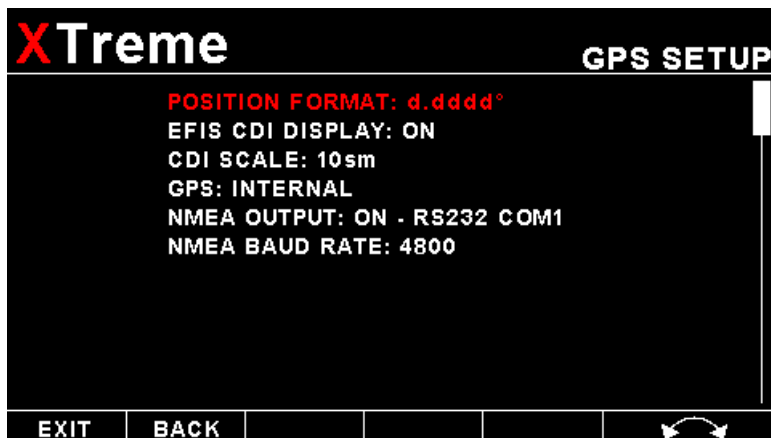

### **POSITION FORMAT:**

Select the display format of the GPS latitude and longitude.

### **EFIS CDI DISPLAY:**

Select "ON" to enable the EFIS CDI display at the bottom of the EFIS displays.

### **CDI SCALE:**

Use this function to adjust the CDI scale to either 1, 2, 5 or 10.

### **GPS:**

Select "INTERNAL" if you want to use the internal GPS (default) or "EXTERNAL" if using an external GPS receiver. Select which serial port the GPS receiver is connected to if using an external GPS.

If an external GPS is used then it must output the following NMEA sentences

- GGA - Global positioning system fix data
- RMC – Recommended minimum specific GNSS data
- GSA – GNSS DOP and active satellites
- GSV – GNSS satellites in view

Note: The GPS flight path will only work if the internal GPS receiver is used.

### **GPS BAUD RATE:**

The baud rate defaults to "9600" baud if using the internal GPS otherwise set the baud rate to match the external GPS receiver you are using.

### **NMEA OUTPUT:**

This enables or disables the NMEA output. The XTreme-EFIS will output the NMEA GPRMC and GPGLA messages. Select which serial port the NMEA output must use.

### **NMEA BAUD RATE:**

Select the baud rate of the NMEA output.

## 4.10 Slip Setup

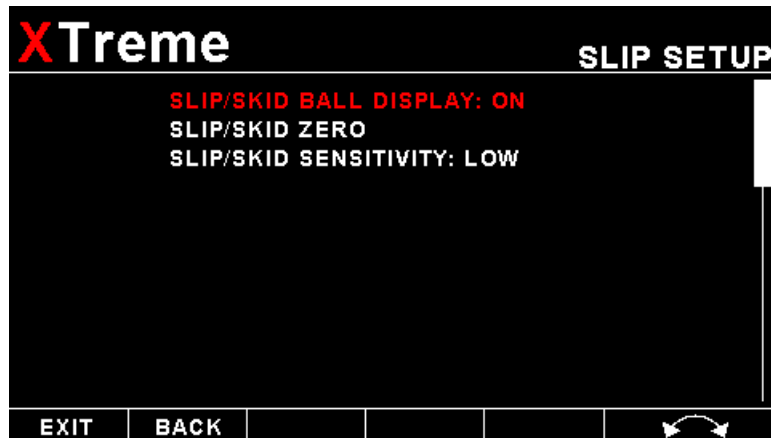

### ***SLIP / SKID BALL DISPLAY:***

Select if you would like to enable the slip indicator to be shown on the bottom of the display.

### ***SLIP / SKID ZERO:***

This function allows you to set your slip indicator to exactly zero even if your aircraft tends to fly slightly wing down. The procedure is to place the aircraft in a stable, straight and level attitude during calm flight conditions and then select this function. To cancel the correction, place your sensor absolutely horizontal (use a spirit level) and select the function again.

### ***SLIP/SKID SENSITIVITY:***

Select if you want the slip to have a high sensitivity or a low sensitivity setting.

## 4.11 G-force Setup

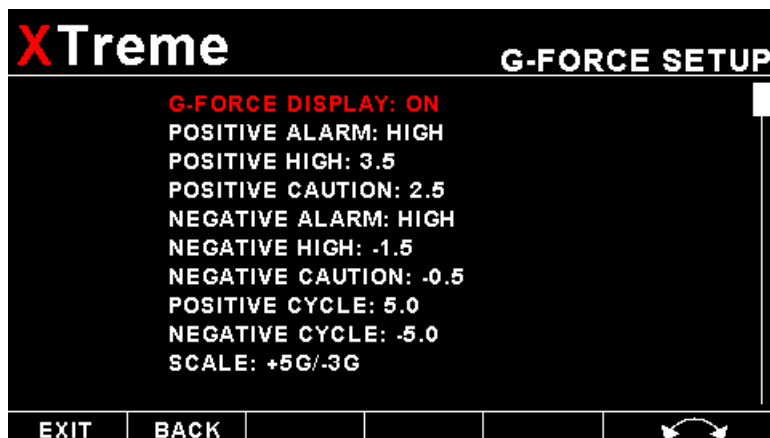

### **G-FORCE DISPLAY:**

Select "ON" to enable the G-Force display.

### **POSITIVE ALARM:**

Select if the G-force alarm must be activated on the positive high value or the positive caution value.

### **POSITIVE HIGH:**

This is the positive G-force high value. This is the start of the positive red section of the G-force indicator.

### **POSITIVE CAUTION:**

This is the positive G-force caution value. This is the start of the positive yellow section of the G-force indicator.

### **NEGATIVE ALARM:**

Select if the G-force alarm must be activated on the negative high value or the negative caution value.

### **NEGATIVE HIGH:**

This is the negative G-force high value. This is the start of the negative red section of the G-force indicator.

### **NEGATIVE CAUTION:**

This is the negative G-force caution value. This is the start of the negative yellow section of the G-force indicator.

### **POSITIVE CYCLE:**

Set the positive G-force limit above which the cycle counter should increment. This would typically be set to the maximum allowable G-force rating of your aircraft (positive G-force). The cycle count is retained if power is removed.

### **NEGATIVE CYCLE:**

Set the negative G-force limit above which the cycle counter should increment. This would typically be set to the maximum allowable G-force rating of your aircraft (negative G-force). The cycle count is retained if power is removed.

### **SCALE:**

Select the scale of the G-force graphic indicator.

### 4.12 Timers Setup

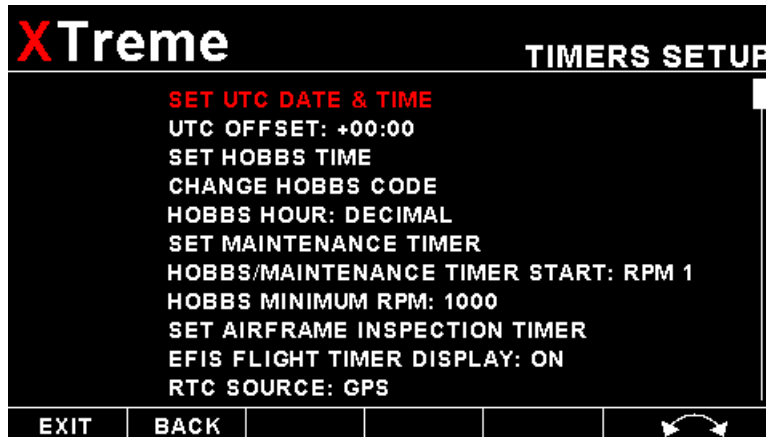

**SET UTC DATE & TIME:**

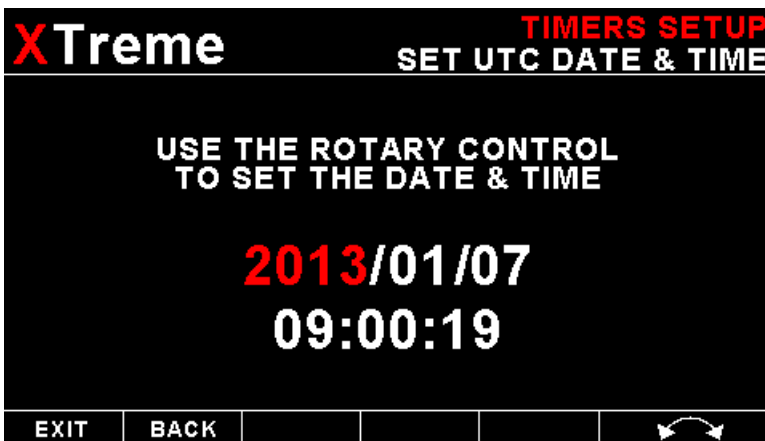

Use the rotary control to set the UTC date & time in the internal RTC.

**UTC OFFSET:**

Enter the UTC offset for your location. The UTC offset can be adjust in half an hour increments.

**SET HOBBS TIME:**

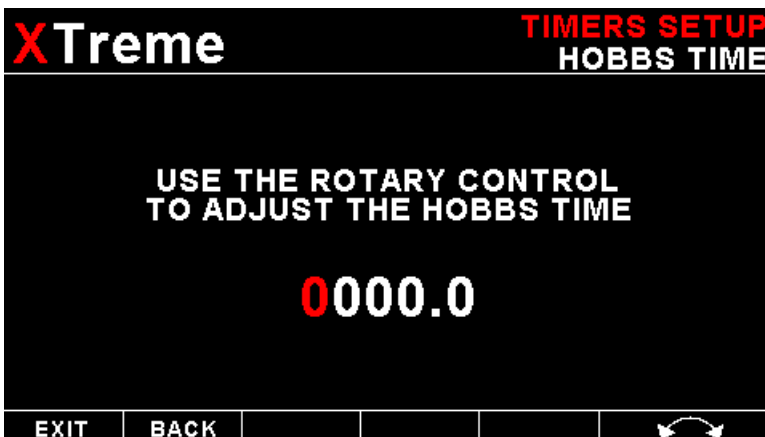

This function allows you to set the engine Hobbs meter to any value. Typically, you would use this function to set the Hobbs meter to the current known engine time. Use the rotary control to change the value. Press the rotary control to accept and exit the menu option. If the Hobbs code is set to another value beside zero, then the pilot will be prompted to enter the Hobbs access code before allowing him to change the Hobbs time. This feature is useful for chartered and flying school planes.

**CHANGE HOBBS CODE:**

This menu option allows you to change the Hobbs access code. You will first be prompted to enter the current code followed by entering in a new code followed by re-entering the new code. If the new code and the re-entered code is the same, then the Hobbs access code will be changed. **Default code is 0000.**

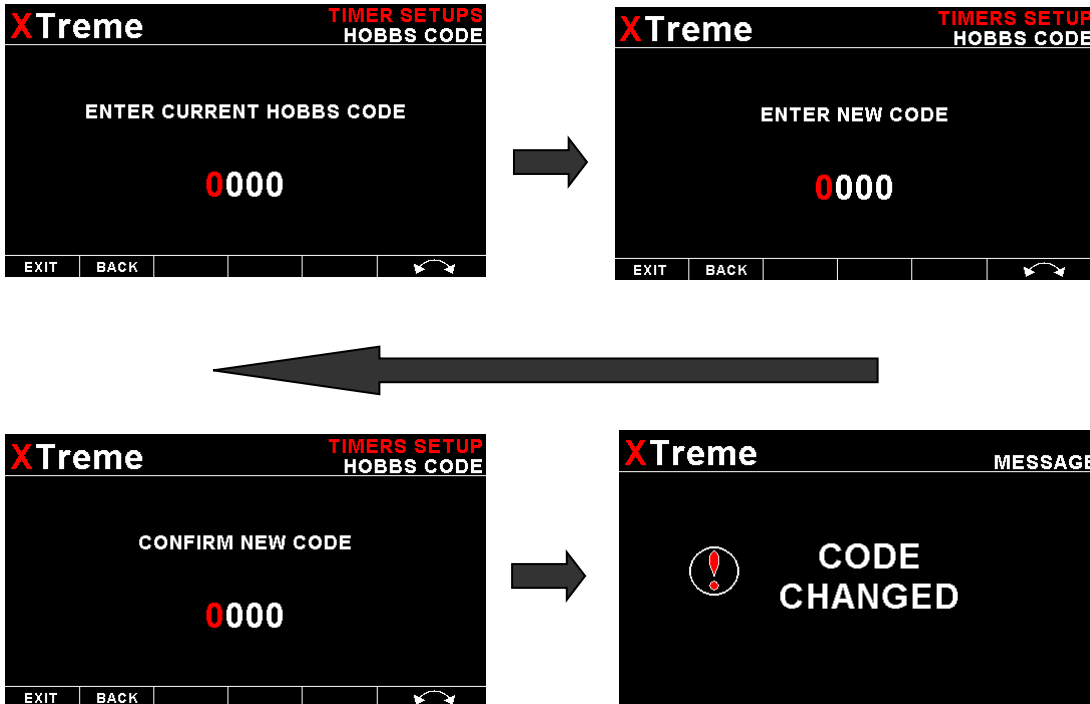

**HOBBS HOUR:**

Select if you would like the hour to be displayed in decimal fractions or minutes.

**SET MAINTENANCE TIMER:**

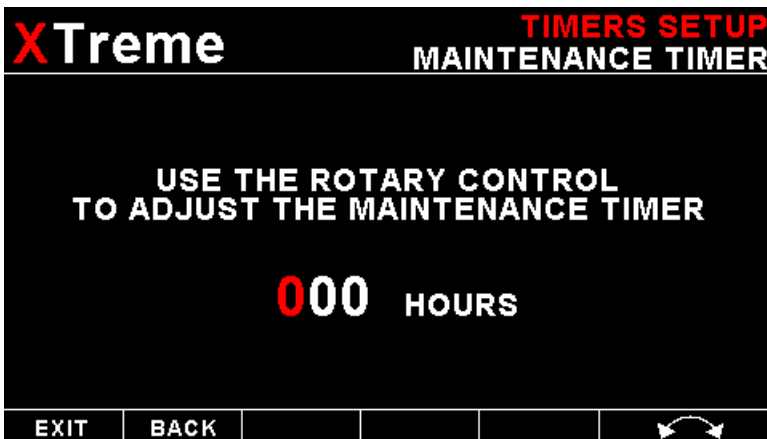

These timers allow you to keep track of engine maintenance interval. Set the timer when you have serviced your engine. A typical time might be 50 hours. This function allows you to set an engine maintenance timer. This timer is set in engine hours and it will count down to zero when the engine RPM is greater then the "HOBBS MINIMUM RPM". A good use for this function is to set the hours until your next spark plug change or engine inspection. Use the rotary control to change the value.

**HOBBS / MAINTENANCE TIMER START:**

Select what source will start the Hobbs and Maintenance timers. A selection between Power, RPM 1 or RPM 2 can be made

**HOBBS MINIMUM RPM:**

Enter the RPM limit in which the Hobbs timer / Maintenance timer must start incrementing

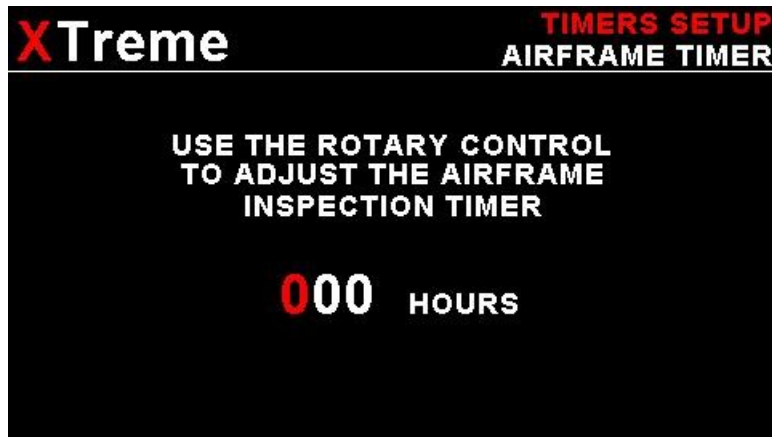

**SET AIRFRAME INSPECTION TIMER:**

This timer operates similar to the engine maintenance timer but is based on flight time. You might use it to schedule thorough airframe checks at intervals, perhaps every 25 or 50 hours.

**EFIS FLIGHT TIMER DISPLAY:**

This enables or disables the flight timer on the EFIS and MFD displays.

**RTC SOURCE:**

Select if you want the RTC UTC time to come from the GPS receiver or the internal RTC. Both real time clocks are powered by an internal 3V lithium coin cell battery. The internal battery can be replaced by unscrewing the 5 screws holding the back and front enclosures together. Delicately replace the battery. The battery is a CR2032 coin cell.

### 4.13 Data Recording Setup

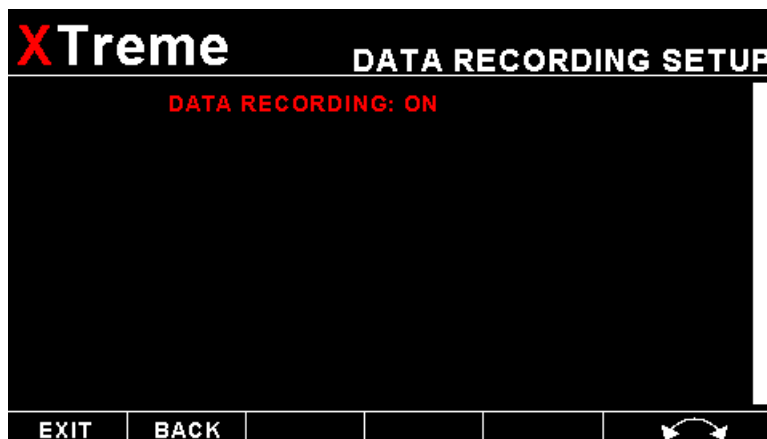

The XTreme-EFIS has the ability to act as a black box recorder, recording flight data directly onto an inserted SD card for later playback and investigation. Data is logged to s SD card in a Comma Separated Values (.CSV) file that can easily be opened in a spreadsheet or text viewer type program. The recorded data can also be viewed in the free XTreme Data Viewer PC program.

The XTreme-EFIS records the engine data as well as the GPS data once per second only WHEN A VALID FLIGHT IS DETECTED (AUTOMATIC OR MANUAL FLIGHT DETECT MODE).

**DATA RECORDING ON:**

Selecting “ON” will enable the data recording functionality.

### Output file format .CSV (Comma Separated Values)

The XTreme-EFIS will create a Comma Separated Values (.csv) file with the date as the filename. A new file is created every time the date changes. The file is created in the root directory of the SD card.

Below is the format of the .CSV data

Date & Time:

- Hobbs Minutes: Hobbs time in minutes
- Maintenance Time: Maintenance time in hours
- Volts: Volts in V
- RPM 1: RPM 1 value
- RPM 1 (%): RPM 1 value in percentage
- RPM 2: RPM 2 value
- RPM 2 (%): RPM 2 value in percentage
- Oil Temperature: Temperature in Degrees C
- Oil Pressure: Pressure in psi
- Aux 1 Channel Type: 0=Off  
1=Pressure  
2=Temperature  
3=Current  
4=Generic

Aux 1 Channel Value:	Pressure in psi Temperature in Degrees C Current in A Generic in user units
Aux 2 Channel Type:	0=Off 1=Pressure 2=Temperature 3=Current 4=Generic
Aux 2 Channel Value:	Pressure in psi Temperature in Degrees C Current in A Generic in user units
Manifold Pressure:	Manifold pressure in mBar
Current:	Current in A
CJC:	Cold junction temperature in Degrees Celsius
TC1:	Thermocouple channel 1 in Degrees Celsius
TC2:	Thermocouple channel 2 in Degrees Celsius
TC3:	Thermocouple channel 3 in Degrees Celsius
TC4:	Thermocouple channel 4 in Degrees Celsius
TC5:	Thermocouple channel 5 in Degrees Celsius
TC6:	Thermocouple channel 6 in Degrees Celsius
TC7:	Thermocouple channel 7 in Degrees Celsius
TC8:	Thermocouple channel 8 in Degrees Celsius
TC9:	Thermocouple channel 9 in Degrees Celsius
TC10:	Thermocouple channel 10 in Degrees Celsius
TC11:	Thermocouple channel 11 in Degrees Celsius
TC12:	Thermocouple channel 12 in Degrees Celsius
Fuel Flow 1:	Fuel Flow 1 in Liters per Hour
Fuel Flow 2:	Fuel Flow 2 in Liters per Hour
Fuel Level 1:	Fuel Level 1 in Liters
Fuel Level 2:	Fuel Level 2 in Liters
Fuel Pressure:	Fuel pressure in psi
OAT:	OAT temperature in Degrees Celsius
Latitude:	Latitude in decimal degrees. Negative is South
Longitude:	Longitude in decimal degrees. Negative is West
SOG:	GPS speed in mph
COG:	GPS Coarse over ground in degrees
Altitude:	Altitude in feet (Referenced to 1013.25mB)
Altitude:	Altitude in feet
Local Pressure:	Local pressure in millibars

VSI:	Vertical speed in ft/min
Airspeed:	Airspeed in mph
Heading:	Magnetic heading in degrees
G-force:	G-Force in G

### 4.13.1 XTreme Data Viewer PC program

The recorded data file can be viewed using the free XTreme Data Viewer PC program. The program can be downloaded from the MGL Avionics website.

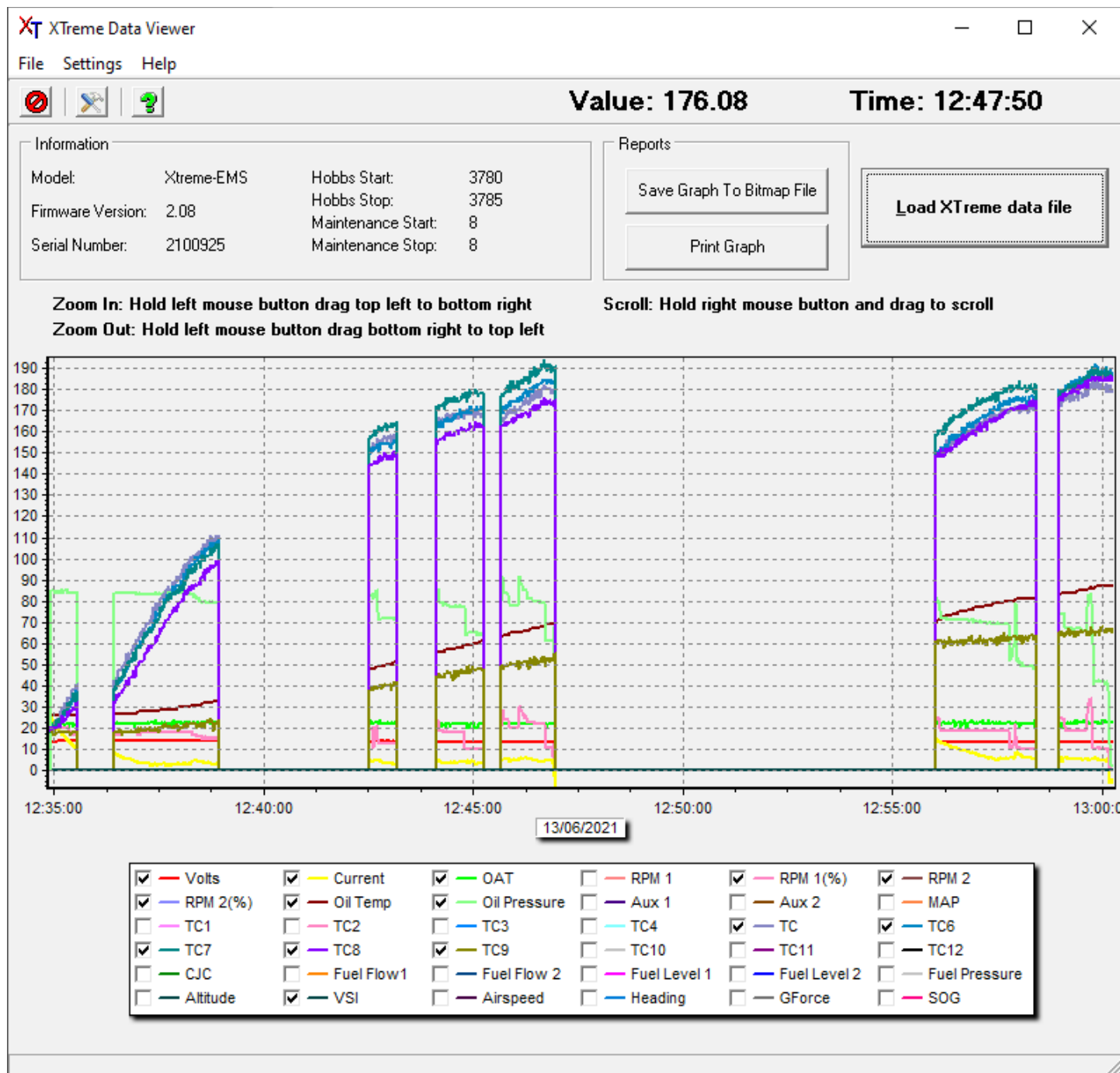

## 4.14 Display Setup



The display setup menu option allows the pilot to select if certain display screens must be shown or not when toggling through the displays using the left or right most soft keys.

### **EFIS DISPLAY:**

Select "ON" to display the full screen EFIS screen.

### **EFIS/EMS DISPLAY:**

Select "ON" to display the 2/3 screen EFIS screen and 1/3 engine monitoring screen.

### **EFIS/HSI DISPLAY:**

Select "ON" to display the 2/3 screen EFIS screen and 1/3 HSI screen.

### **VFR DISPLAY:**

Select "ON" to display the full screen VFR screen.

### **VFR/EMS DISPLAY:**

Select "ON" to display the 2/3 screen VFR screen and 1/3 engine monitoring screen.

### **EMS DISPLAY:**

Select "ON" to display the full screen engine monitoring screen.

### **GPS DISPLAY:**

Select "ON" to display the GPS information screen.

### **INFO/CHECKLIST DISPLAY:**

Select "ON" to display the Information/Checklist screen.

### 4.15 Miscellaneous Setup

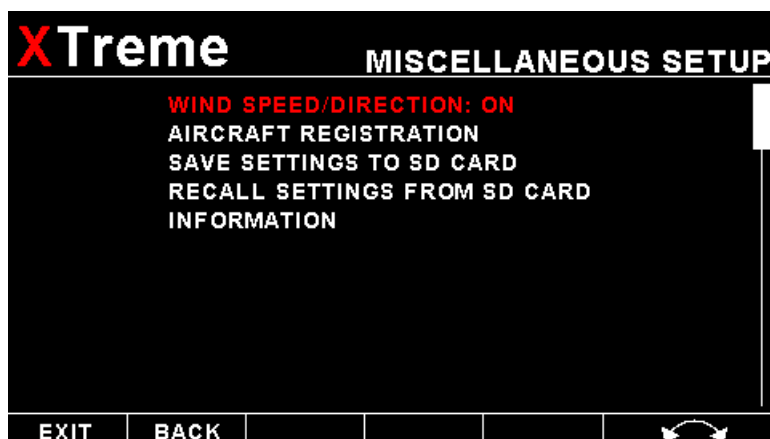

**WIND SPEED/DIRECTION:**

Select if you want the wind speed / direction displayed on the EFIS and MFD display screens.

The following variables must be available in order to calculate the wind speed/wind direction

- A valid 2D or 3D GPS fix
- Magnetic heading (Requires MGL Avionics SP6 magnetic compass)
- TAS

**AIRCRAFT REGISTRATION:**



Enter your aircraft registration. A maximum of 8 characters can be entered. The aircraft registration is displayed on the start up (Splash) screen.

**SAVE SETTINGS TO SD CARD:**

Select this option to save all the XTreme-EFIS settings to the SD card. This is useful when setting up the instrument on the PC simulator and then later transferring the settings on the instrument itself. A file called "XTREME3.EFS" will be created in the root directory of the SD card.

***RECALL SETTINGS FROM SD CARD:***

Select this option to recall all the XTreme-EFIS settings from the SD card. This is useful when setting up the instrument on the PC simulator and then later transferring the settings to the instrument itself. The settings will be loaded from a file called "XTREME3.EFS" in the root directory of the SD card.

***INFORMATION:***

This displays information about the XTreme-EFIS unit.

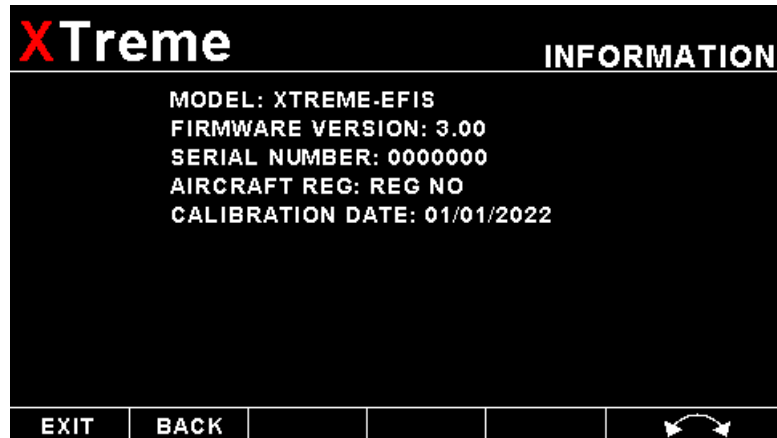



### 4.16 Transponder Setup

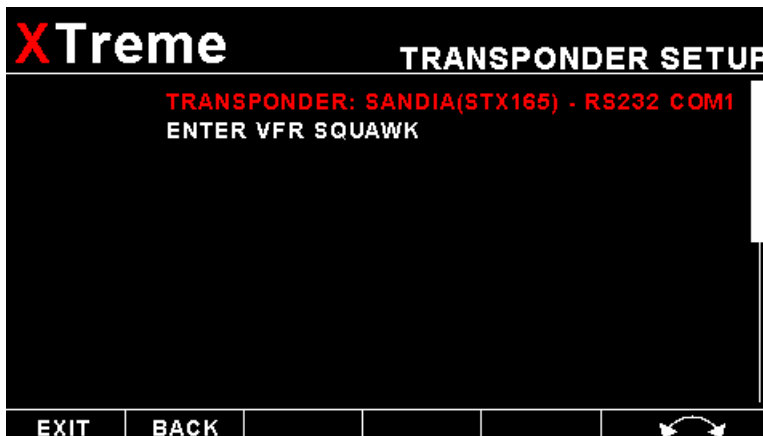

**TRANSPONDER:**

Select which XTreme-EFIS serial port the Sandia transponder is connected to.

**ENTER VFR SQUAWK:**

Enter the VFR squawk code

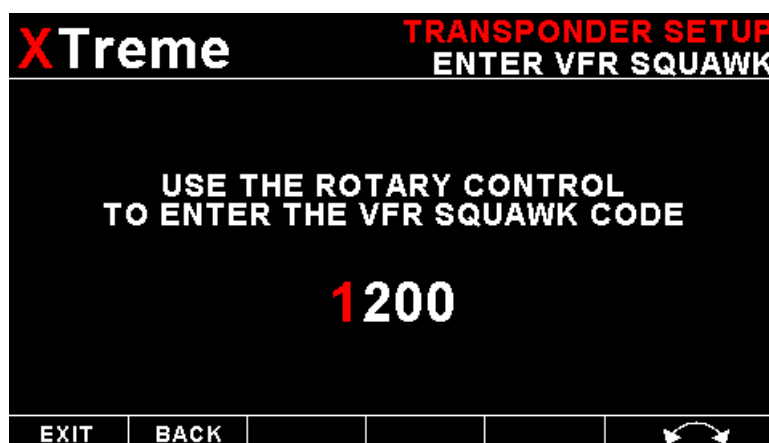

### 4.17 Autopilot Setup

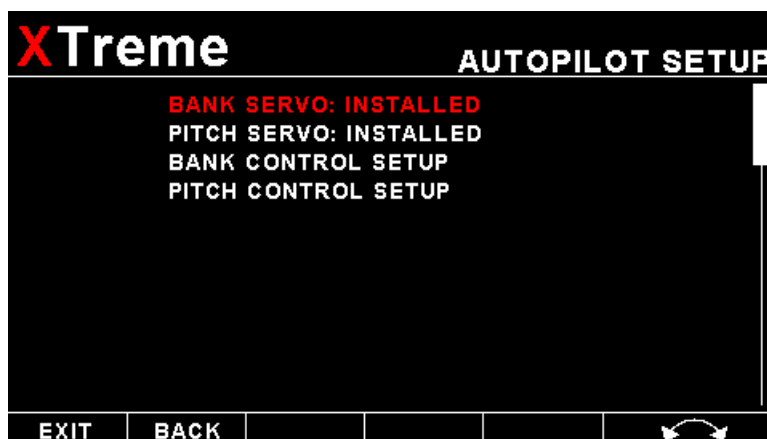

**PLEASE SEE MGL AVIONICS AUTOPILOT DOCUMENTATION FOR MORE IN DEPTH EXPLANATION REGARDING THE AUTOPILOT SETUP AND USE.**

**BANK SERVO:**

Select if the bank servo is installed.

**PITCH SERVO:**

Select if the pitch servo is installed.

**BANK CONTROL SETUP:**

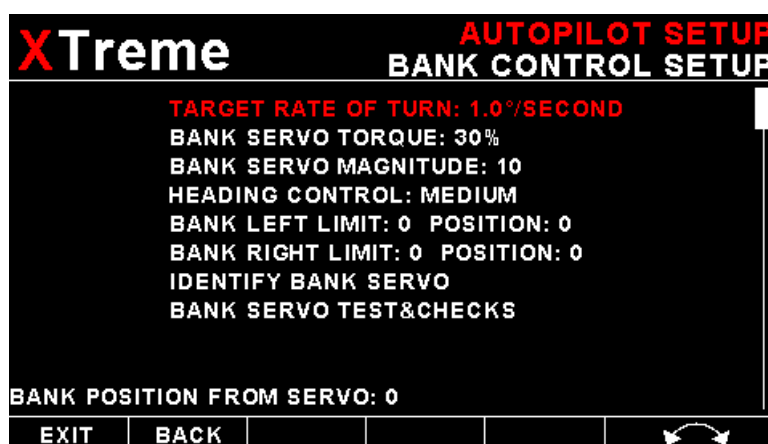

**TARGET RATE OF TURN:**

Select your desired target rate of turn when capturing a new heading.

Typical turn rates range from 2.0 to 3.0 degrees per second. A rate of 3.0 degrees per second corresponds to a rate one turn (360 degrees in two minutes). This value is used for large heading errors, for smaller errors this value is suitably scaled down to ensure smooth track intercept and hold. For fast aircraft, it is recommended to choose lower rates of turn to avoid the bank angle from getting too steep.

**BANK SERVO TORQUE:**

Here you select the maximum torque the servo will be able to hold before slipping. 100% is the maximum possible torque. Lower this number if you need the servo to slip at a lower torque setting. You should select a setting that allows an easy override of the servo by the pilot but it should remain high enough so it will not slip during higher control force loads that may be experienced during turbulence or out-of-trim conditions.

**BANK SERVO MAGNITUDE:**

This setting selects the amount of servo movement for a given bank angle error (the error between desired bank angle and actual bank angle). This value is selected during a test flight (next chapter). Set this value to "10" before the first flight. A higher value produces more servo movement. The aim is to find a value that results in rapid correction of an error without over correction. Typical values are from 10 to 30.

**HEADING CONTROL:**

Using this setting you select the amount of bank angle to apply to correct a given track error. This allows you to select a "gentle" or "forceful" intercept. Select: Slow, Medium or Fast to best suit your aircraft.

**BANK LEFT/RIGHT LIMIT:**

**You cannot use or test the MGL Avionics servos until you have completed the following procedure:**

These functions are used to set the left and right limits as well as the required servo direction. Move the stick to the maximum left bank position you would like the autopilot to fly (this may be slightly less than the maximum left bank position that can be flown). You should see the current position shown in the range of 0 to 4095 as you move the stick. Select the function when you have reached the desired position. This will copy the current position into the limit field. Repeat this procedure for the right bank position. It does not matter which side you do first and you can do this as many times as needed. Note: You need to exit all menus to permanently store these settings. If you do not see the current position field number changing with servo arm position, please check that the servo is powered and that the serial communications link has been connected correctly.

**IDENTIFY BANK SERVO:**

The servos need to be configured so they know what function they are assigned to. You can identify a servo if the autopilot is not engaged and no flight is active.

In order to identify a servo (assign its function), **only one servo is allowed to be connected.**

Please temporarily disconnect all other servos. Once you have a single servo connected you can use the "IDENTIFY BANK SERVO" function. Example: You have the bank servo connected and powered. You then send the "IDENTIFY BANK SERVO" command by selecting the relevant function.

You will receive a confirmation message. After a few seconds you will be shown a message either confirming that the servo has been successfully configured or that no data has been received. If the procedure is not successful, please check your power supply and signal wiring from the EFIS to the servo.

**Before you can use the MGL servos you must identify them using the procedure described here.** You can repeat this procedure and reassign servos as needed.

**If you change servos or re-assign servos you must perform the identification procedure and select servo positions. Servos are unique and internal position numbers vary between servos.**

**Recommended first settings:**

Target rate of Turn: Slower aircraft: 3.0, faster aircraft: 2.0  
Bank Servo torque: As needed to ensure pilots ability to override servo.  
Bank Servo magnitude: 10  
Heading control: Medium

**BANK SERVO TEST & CHECKS:**

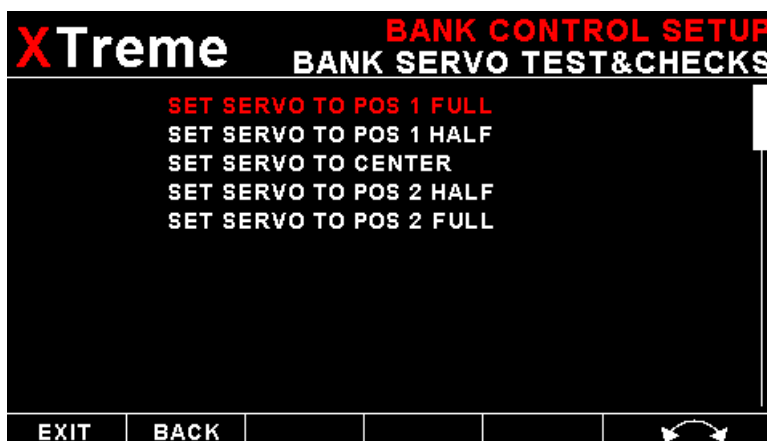

Use the provided functions to move the servo arm to the positions provided. Ensure that servo movement is smooth and no danger exists that could result in binding controls or jamming of control surfaces. Ensure that with the servo engaged there is no noticeable play between control surface and servo arm. Every small servo arm movement must result in a corresponding movement of the control surface.

You must guarantee that no reason exists that could result in servo or servo linkage to the control surface causing any form of danger to the aircraft in case of malfunction or any other cause. Ensure that the pilot will be able to take control from the servo in an emergency under any and all circumstances.

**PITCH CONTROL SETUP:**

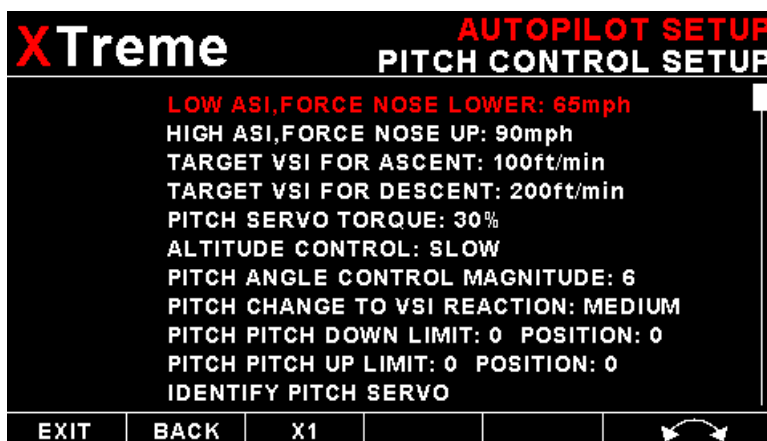

***LOW ASI, FORCE NOSE LOWER:***

Select the minimum allowable airspeed during a climb. The autopilot system will control the pitch gyro during a climb such that when this airspeed limit is reached, a pitch down command will be issued to regain airspeed above this value. Airspeed has priority over ascent or descent rate. Please choose this value carefully to prevent issues during climbing. Airspeed will reduce during climbs if power is not added. Choose a value that is well above stall speed but not high enough to interfere with the climb.

***HIGH ASI, FORCE NOSE UP:***

Select the maximum allowable airspeed during a descent. The autopilot system will control the pitch gyro during descent such that when this airspeed limit is reached, a pitch up command will be issued to retain airspeed below this value. Airspeed has priority over ascent or descent rate.

***TARGET VSI FOR ASCENT:***

Select the desired vertical rate of climb for ascent to a new flight altitude. This rate will be used as target if the new altitude is relatively far away. Avoid the temptation to select a climb rate that is higher than what your aircraft can sustain.

***TARGET VSI FOR DESCENT:***

Select the desired vertical rate of descent to a new flight altitude. This rate will be used as target if the new altitude is relatively far away. Select a target rate of descent that is achievable using elevator control only, taking into account maximum airspeed as selected for the descent.

***PITCH SERVO TORQUE:***

This entry will only show if you have the MGL Avionics servo selected. Here you select the maximum torque the servo will be able to hold before slipping. 100% is the maximum possible torque. Lower this number if you need the servo to slip at a lower torque setting. You should select a setting that allows an easy override of the servo by the pilot but it should remain high enough so it will not slip during higher control force loads that may be experienced during moderate turbulence.

***ALTITUDE CONTROL:***

This setting adjust the speed that a pitch angle change may take. Higher values will result in a more aggressive change of pitch angle to follow a given vertical rate. Lower values result in a softer rate of pitch angle change. Select: Slow, Medium or Fast to best suit your aircraft.

***PITCH ANGLE CONTROL MAGNITUDE:***

This setting sets the amount of servo movement to apply for a given pitch angle change. If this setting is too low, the aircraft will take too long to change pitch angle and is not able to hold a desired pitch angle. If the value is too high, the pitch control can overreact resulting in a rapid and forceful oscillation around the pitch axis. Higher performance aircraft or aircraft that are very pitch sensitive (very small amounts of control movement result in a large pitch angle change) will need smaller settings (typically around 5-8) while slower aircraft tend to use values around 8 -15. This is the first and most critical calibration item that needs to be set as described below.

***PITCH CHANGE TO VSI REACTION:***

This setting informs the autopilot how long it will take for a pitch control surface change to affect the desired vertical rate change. This is related in part to the aircraft's mass and in part to the effectiveness of the aircraft's pitch control surface (elevator).

***PITCH DOWN / UP LIMIT:***

***You cannot use or test the MGL Avionics servos until you have completed the following procedure:***

These functions are used to set the pitch up and down limits as well as the required servo direction. Move the stick to the maximum pitch up position you would like the autopilot to fly (this may be slightly less than the maximum up position that can be flown). You should see the current position shown in the range of 0 to 4095 as you move the stick. Select the function when you have reached the desired position. This will copy the current position into the limit field. Repeat this procedure for the pitch down position. It does not matter which you do first and you can do this as many times as needed. Note: You need to exit all menus to permanently store these settings. If you do not see the current position field number changing with servo arm position, please check that the servo is powered and that the serial communications link has been connected correctly. Also ensure that you have selected the correct port on the COM Extender for this servo.

**Recommended first settings**

Low ASI: Slightly above the aircraft's stall speed.

High ASI: Slightly below or at the aircraft's maximum cruise speed.

Target VSI for ascent: 400 ft/min or as suitable for aircraft.

Target VSI for descent: 400 ft/min or as suitable for aircraft.

Altitude control: Medium.

Pitch Angle control magnitude: 10.

Pitch change to VSI reaction: Medium.

***IDENTIFY PITCH SERVO:***

The servos need to be configured so they know what function they are assigned to. You can identify a servo if the autopilot is not engaged and no flight is active.

In order to identify a servo (assign its function), **only one servo is allowed to be connected.**

Please temporarily disconnect all other servos. Once you have a single servo connected you can use the "IDENTIFY PITCH SERVO" function. Example: You have the pitch servo connected and powered. You then send the "IDENTIFY PITCH SERVO" command by selecting the relevant function.

You will receive a confirmation message. After a few seconds you will be shown a message either confirming that the servo has been successfully configured or that no data has been received. If the procedure is not successful, please check your power supply and signal wiring from the EFIS to the servo.

**Before you can use the MGL servos you must identify them using the procedure described here.** You can repeat this procedure and reassign servos as needed.

If you change servos or re-assign servos you must perform the identification procedure and select servo positions. Servos are unique and internal position numbers vary between servos.

**PITCH SERVO TEST & CHECKS:**

Use the provided functions to move the servo arm to the positions provided. Ensure that servo movement is smooth and no danger exists that could result in binding controls or jamming of control surfaces. Ensure that with the servo engaged there is no noticeable play between control surface and servo arm. Every small servo arm movement must result in a corresponding movement of the control surface.

You must guarantee that no reason exists that could result in servo or servo linkage to the control surface causing any form of danger to the aircraft in case of malfunction or any other cause. Ensure that the pilot will be able to take control from the servo in an emergency under any and all circumstances.

### 4.18 Sensor Info



XTreme		SENSOR INFO	
STATIC: 0.00mb	0.0°C	VOLTS: 0	
PITOT: 0.00mb	0.0°C	CURRENT: 0	
RPM 1: 31000		OAT: 0	
RPM 2: 0		MAP: 0	
FUEL FLOW 1: 0		OIL TEMPERATURE: 0	
FUEL FLOW 2: 0		OIL PRESSURE: 0	
FUEL LEVEL 1: 0			
FUEL LEVEL 2: 0		AUX 1/CHT 1: 0	
FUEL PRESSURE: 0		AUX 2/CHT 2: 0	
EXIT	BACK		

These values are mainly used for debugging purposes.



## 5 Startup (Splash) Screen

### Creating your own Startup (Splash) Screen:

#### You will need:

- A bitmap picture of your choice (\*.BMP, 480x272 pixel resolution)
- The BMP to MIF converter tool (can be downloaded free of charge from <http://www.mglavionics.co.za> or can be found on the XTreme SD card).

The BMP to MIF program is used to convert images in Windows BMP format to MIF format. You can use this program to make your own startup screen (Splash screen) and graphic information display screens. The color depth is limited to 256 colors.

Run the XTreme Image Maker program.

Load an image file (and remember the location), select the resolution as width(480) and height (272) and press the process button. The new MIF image will be located in the same directory as the source (BMP) file. If the original file was not named Splash.BMP, rename the new \*.MIF file to Splash.MIF, and copy the Splash.MIF file into the root directory of your SD card.

The picture will be displayed when the unit is powered up.

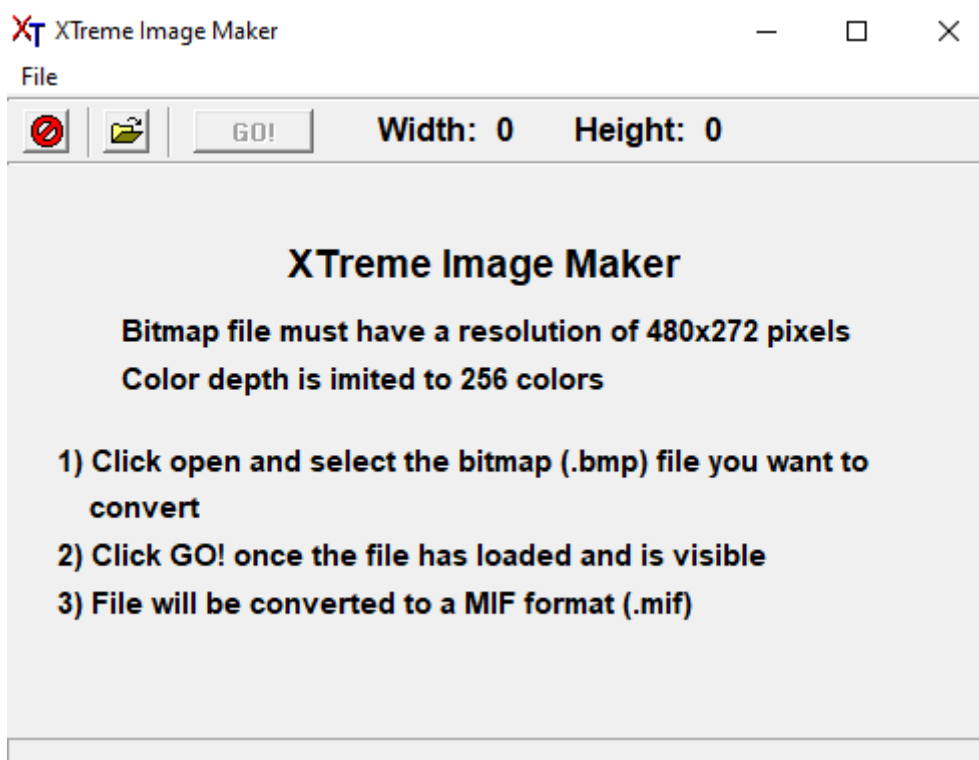

## 6 Loading factory default settings

Press and hold the left and right most soft keys simultaneously on power up to load default factory settings. The following screen will be displayed:

**LOADING DEFAULT  
SETTINGS**

## 7 Alarm condition

**ALARM  
RPM HIGH**

**879**

If an alarm condition occurs the following will happen:

- The item causing the alarm condition will flash on the screen
- An alarm warning message will be displayed on the screen
- An external alarm switch will close

The alarm warning message and switch closure will remain until any button is pressed or until the condition(s) that activated the alarm no longer exist.

The alarm output can be used to switch an external alarm indicator. The external alarm switch is an open collector transistor switch to ground with a maximum rating of 0.5A DC. It is possible to wire the alarm contacts of several Stratomaster instruments in parallel should this be desired.

To avoid false activation of the alarms, the alarm function is only active 10 seconds after the instrument has powered up.

## 8 Cleaning

The unit should not be cleaned with any abrasive substances. The screen is very sensitive to certain cleaning materials and should only be cleaned using a clean, damp cloth.

**Warning:** The XTreme-EFIS is not waterproof. Serious damage could occur if the unit is exposed to water and/or spray jets.

## 9 Specifications

Operating Temperature Range	-10°C to 50°C (14°F to 122°F)
Storage Temperature Range	-20°C to 80°C (-4°F to 176°F)
Humidity	<95% RH non-condensing
Power Supply	8 to 30Vdc
Current Consumption	Approx. 200mA @ 13.8V
Display	4.3" 480x272 pixel, 1000cd/m2 active matrix TFT LCD (Sunlight Readable). Anti-glare coating. LED backlight is user adjustable.
Dimensions	see section 12 for dimensional drawings
Enclosure	3 1/8" (80mm) ABS, black in color, front mounting. See XTreme-EFIS dimensional drawing
Weight	Approx. 270 grams (includes XTreme, cable, GPS antenna & OAT sensor)
Alarm contact current rating	Open collector transistor switch to ground. Maximum rating 0.5A DC
Non-volatile memory storage	100000 write cycles
Warm up time	10 minutes
<b>Altimeter</b>	
Altitude sensor ADC resolution	24 bit
Altimeter range	-1500ft to 35000ft (-457m to 10668m)
Altitude units	ft or m
Baro Correction Range (inHg)	28.00 to 31.00 "Hg
Baro Correction Range (mB)	946 to 1050 mb
Calibration interval	1 Year
<b>Airspeed</b>	
Airspeed sensor ADC resolution	24 bit
Airspeed range	20mph to 350mph
Airspeed resolution	1 mph
Calibration interval	1 Year
<b>VSI</b>	
VSI range	+20ft/min to +-10000ft/min
VSI units	ft/min or m/s
<b>Voltage</b>	
Range	8 to 30V DC
Resolution	0.1V
<b>G-Force</b>	
Range	+10g typical
<b>OAT</b>	
Range	Semiconductor LM335 (STMicroelectronics)
<b>GPS</b>	
Channels	50
Correlators	>1 000 000
Update rate	4 Hz
Time to First Fix (TTFF)	<1 Second
Antenna	External active antenna
Antenna connection	SMA

As with any instrument, regular zeroing is suggested to achieve maximum performance.

# 10 Installation

## 10.1 Altimeter Installation

Connect the static port to a suitable static air pressure line. If you have a slow aircraft or an aircraft where the internal cabin pressure does not change during flight and is equivalent to the outside air pressure you may find that it is not required to connect a static port. For installations in typical ultralight aircraft pods, be aware of possible pressure changes inside the pod during flight caused by ram air or suction effects. This may lead to a false indication of altitude and airspeed. Often these effects are dependent on the current angle of attack of the airflow around your pod. You will need to install a suitable static port in these cases.

Static ports are usually mounted at a strategic position on the rear side of the aircraft fuselage for faster, pressurized aircraft.

The static pressure port take 4mm ID tubing. Use hose clamps to fasten the hose onto the static port.

## 10.2 Airspeed Installation

Connect your pitot tube to the "PITOT TUBE" port.

The XTreme-EFIS allows you to calibrate the airspeed reading. This is done under the "AIRSPEED SETUP" menu item. The main reason for this is to be able to remove errors introduced due to the airflow around your aircraft which may have an effect on your pitot tube pressure.

The pitot pressure port take 4mm ID tubing. Use hose clamps to fasten the hose onto the pitot port.

## 10.3 Pressure Port Dimensions

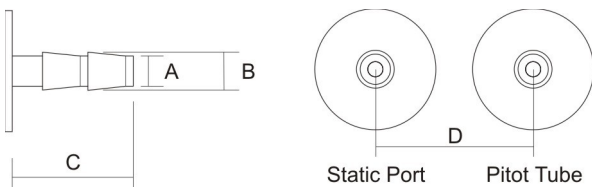

	<b>Inches</b>	<b>Millimeters</b>
<b>A</b>	<b>0.157</b>	<b>4</b>
<b>B</b>	<b>0.197</b>	<b>5</b>
<b>C</b>	<b>0.63</b>	<b>16</b>
<b>D</b>	<b>0.79</b>	<b>20</b>

### 10.4 Connection Diagram

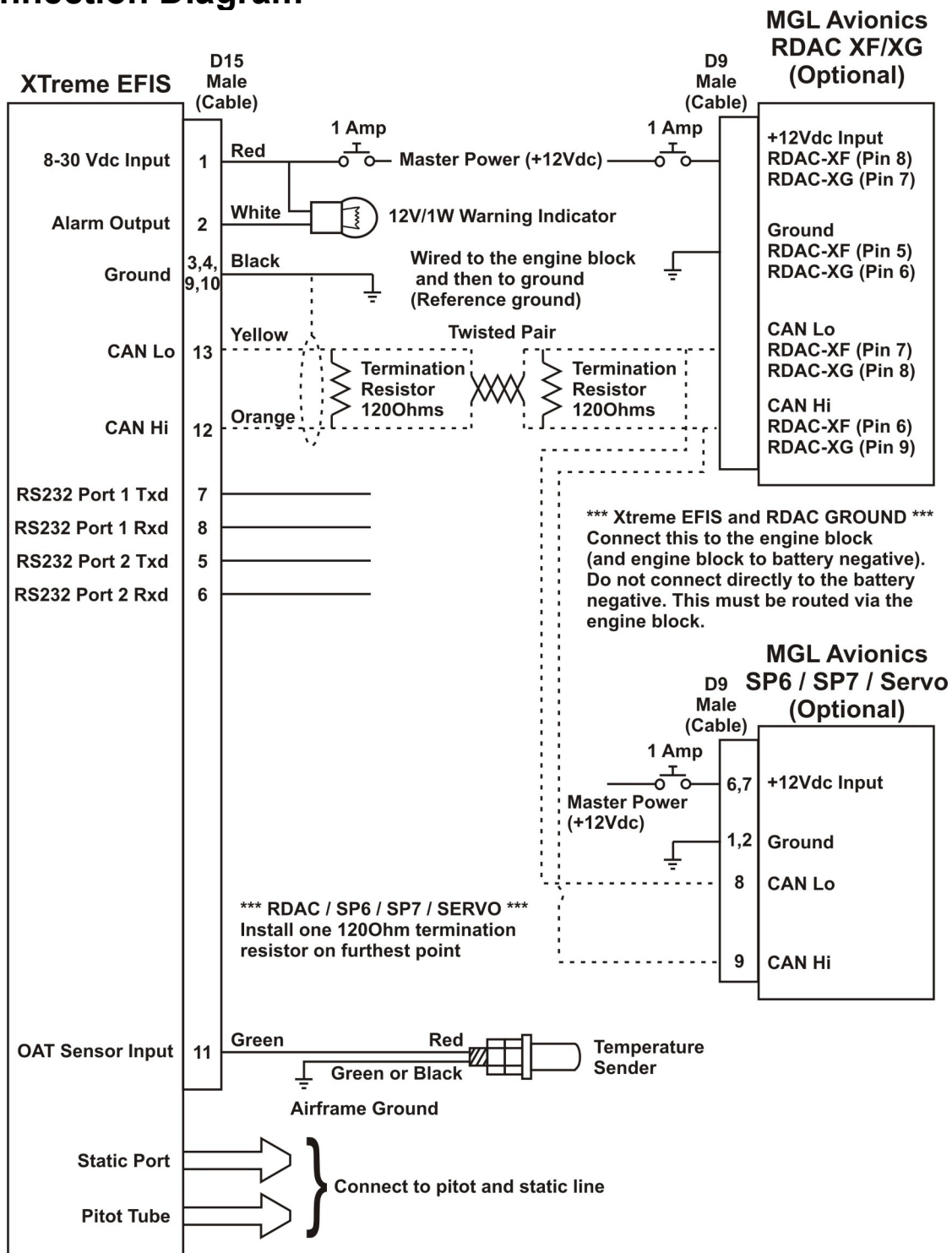

The use of an external 1A fuse is recommended. Connect the supply terminals to your aircrafts power supply. The XTreme-EFIS can be used on both 12V and 24V without the use of any pre-regulators. Ensure that the supply voltage will not drop below 8V during operation as this may result in incorrect readings.

**Please see MGL Avionics SP6/SP7/Servo and RDAC documentation for installation and usage.**

### 10.5 Cable connections

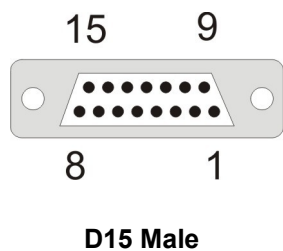

DB 15 Pin	Color	Function
1	Red	8-30Vdc power
2	White	Alarm Output
3,4,9,10	Black	Ground
5	NC	RS232 Port 2 Transmit
6	NC	RS232 Port 2 Receive
7	NC	RS232 Port 1 Transmit
8	NC	RS232 Port 1 Receive
11	Green	OAT Probe
12	Orange	CAN High
13	Yellow	CAN Low
14	NC	No Connection
15	NC	No Connection

NC=Not Connected

The XTreme-EFIS has a D15 Female connector. The connecting cable must have a D15 male connector attached to it.

### 10.6 CNV-ALT (Serial altitude to parallel Gillham code converter)



The CNV-ALT accepts RS232 serial data from a compatible MGL Avionics instrument and produces parallel Gillham codes in a format compatible with mode C transponders. The XTreme-EFIS serial protocol must be set to MGL Avionics.

### 10.7 OAT Probe



Connect the OAT probe red wire to the XTreme-EFIS green wire and the black or green wire to ground.

### 10.8 External RDAC (Remote Data Acquisition) (Optional)

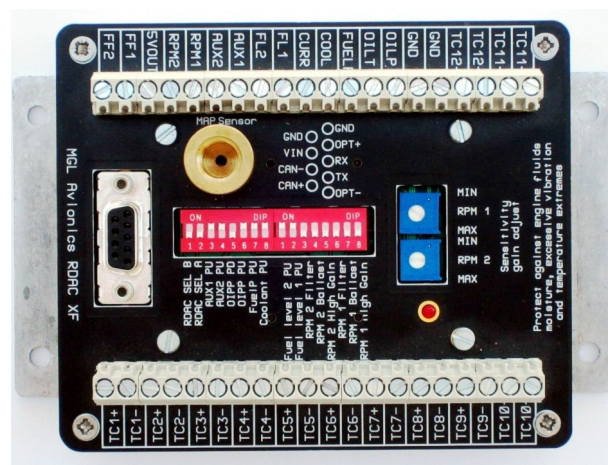

# 11 Firmware upgrades

The XTreme's firmware can be upgraded in the field to the latest version via the SD card. This will keep your XTreme-EFIS up to date with bug fixes and new features.

The name of the firmware file must be called XT3EFIS.FW and it must reside in the root directory of the SD card. When the XTreme-EFIS powers up it will first look at the SD card to see whether the file exists, if it does then it will prompt the user to upgrade the firmware. Use the soft keys at the bottom to select whether to upgrade to the new firmware or to exit the firmware upgrade feature. The XTreme-EFIS also provides a soft key to delete the XT3EFIS.FW file from the SD card to avoid removing the SD card and deleting it with a PC.

If the file does not exist, then the firmware upgrade function is bypassed and the XTremes main program is executed. Please check <http://www.mglavionics.co.za/XTreme.html> regularly for the latest firmware releases.





## 12 Dimensions

### 12.1 Front view

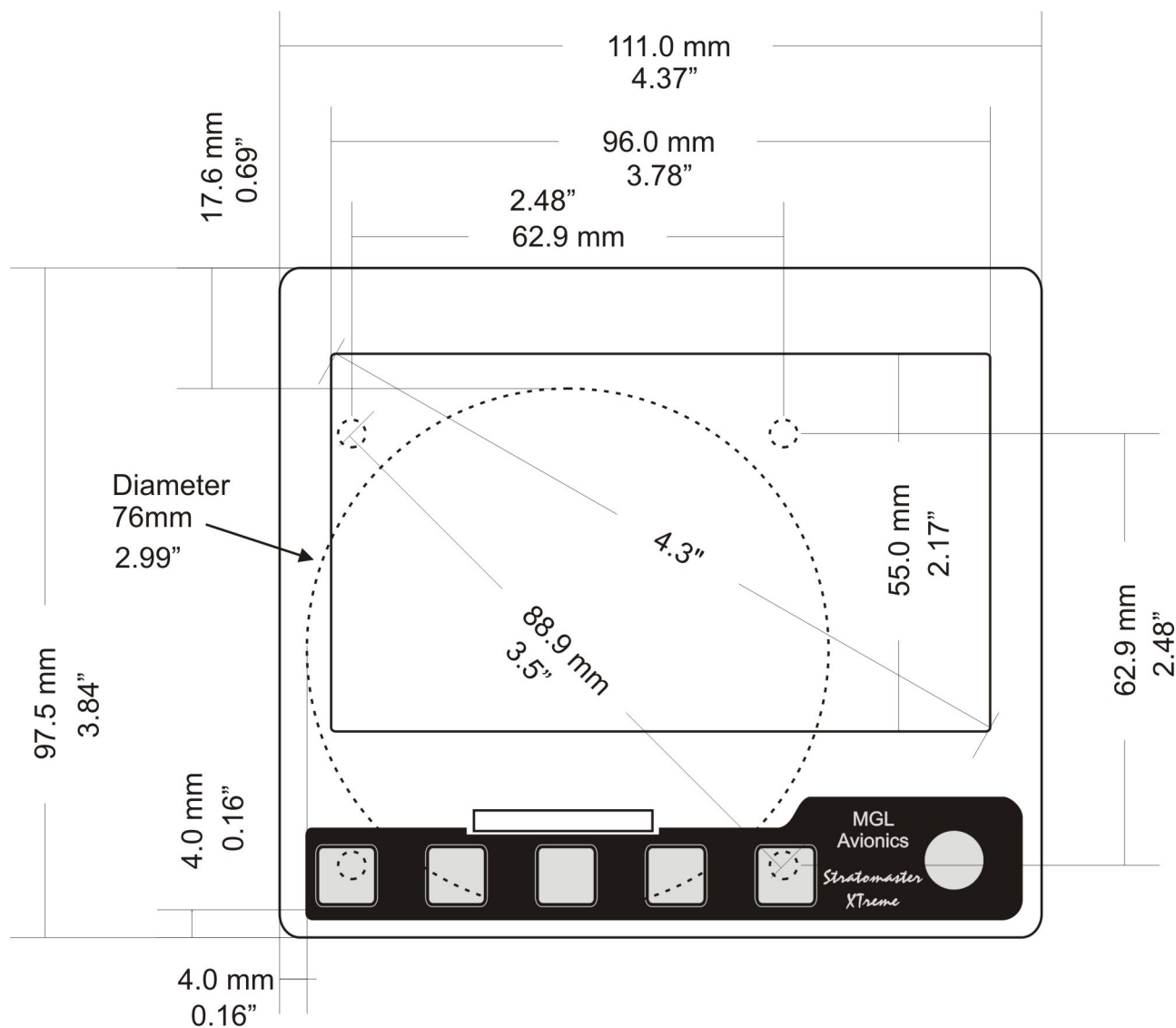

12.2 Side view

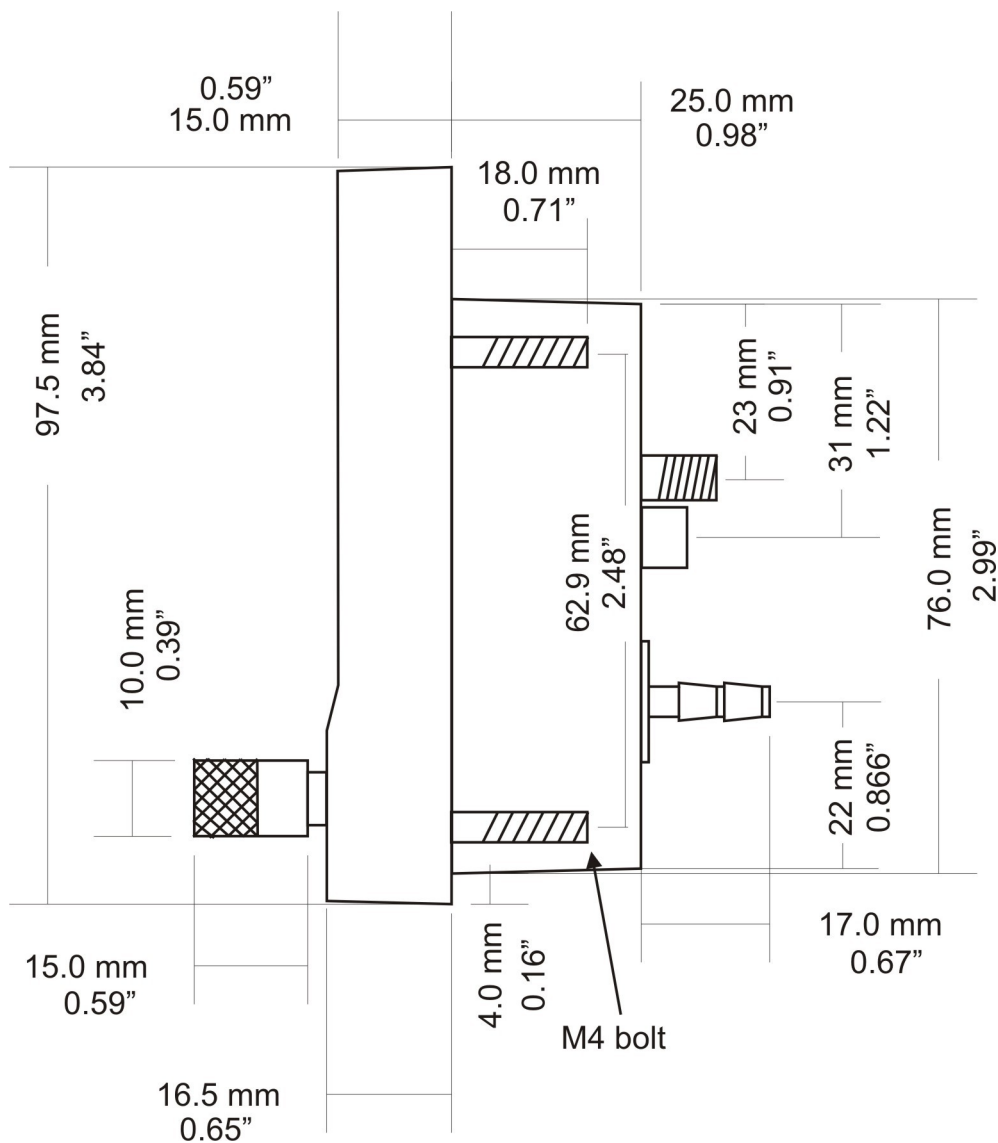

### 12.3 Top view

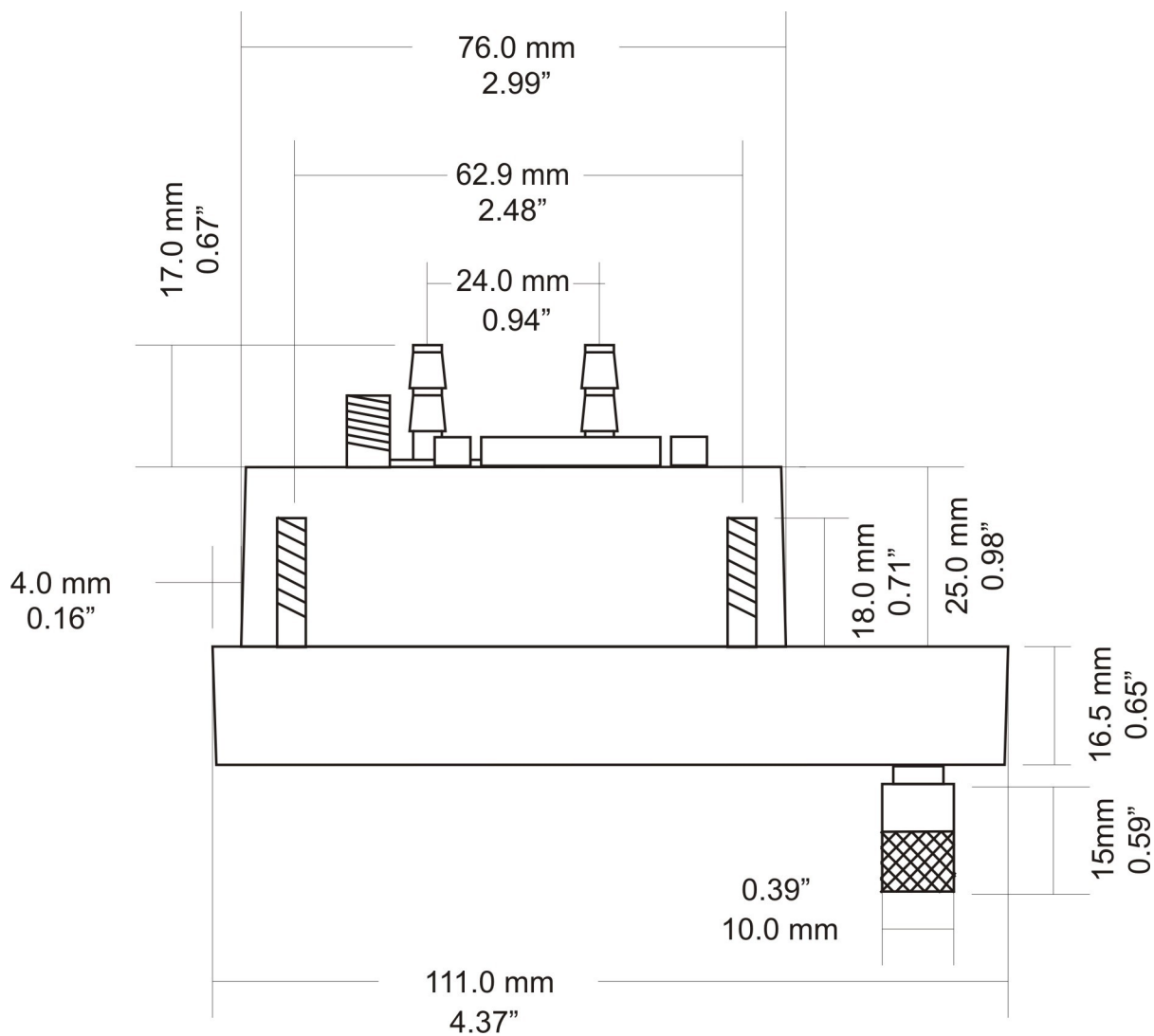

## 13 Warranty

This product carries a warranty for a period of one year from date of purchase against faulty workmanship or defective materials, provided there is no evidence that the unit has been mishandled or misused. Warranty is limited to the replacement of faulty components and includes the cost of labor. Shipping costs are for the account of the purchaser.

**Note:** Product warranty excludes damages caused by unprotected, unsuitable or incorrectly wired electrical supplies and or sensors, and damage caused by inductive loads.

## 14 Disclaimer

Operation of this instrument is the sole responsibility of the purchaser of the unit. The user must make themselves familiar with the operation of this instrument and the effect of any possible failure or malfunction.

This instrument is not certified by the FAA. Fitting of this instrument to certified aircraft is subject to the rules and conditions pertaining to such in your country. Please check with your local aviation authorities if in doubt. This instrument is intended for ultralight, microlight, home built and experimental aircraft. Operation of this instrument is the sole responsibility of the pilot in command (PIC) of the aircraft. This person must be proficient and carry a valid and relevant pilot's license. This person has to make themselves familiar with the operation of this instrument and the effect of any possible failure or malfunction. Under no circumstances does the manufacturer condone usage of this instrument for IFR flights.

### **IMPORTANT NOTICE:**

You must make your own determination if the products sold by MGL Avionics are safe and effective for your intended applications. MGL Avionics makes no representations or warranties as to either the suitability of any of the products we sell as to your particular application or the compatibility of any of the products we sell with other products you may buy from us or anywhere else, and we disclaim any warranties or representations that may otherwise arise by law. Also, we offer no specific advice on how to install any of the products we sell other than passing along anything that may have been provided to us by the manufacturer or other issues. If you are in need of further information or guidance, please turn to the manufacturer, FAA Advisory Circulars and guidance materials, the Experimental Aircraft Association, or other reputable sources.

**Continuing development sometimes necessitates specification changes without notice.**